



CRITICS-study:

ChemoRadiotherapy after Induction chemoTherapy In Cancer of the Stomach

A multicenter randomized phase III trial of neo-adjuvant chemotherapy followed by surgery and chemotherapy or by surgery and chemoradiotherapy in resectable gastric cancer

Leading group: Dutch Colorectal Cancer Group (DCCG)

Principal Investigators:

Radiation oncology

E.P.M. Jansen MD
epm.jansen@nki.nl
The Netherlands Cancer Institute/
Antoni van Leeuwenhoek hospital
Dept. Of Radiation Oncology
Plesmanlaan 121
1066 CX Amsterdam
The Netherlands
T 31 20 5122124
F 31 20 6691101

Prof. M. Verheij MD PhD
m.verheij@nki.nl
The Netherlands Cancer Institute/
Antoni van Leeuwenhoek hospital
Dept. Of Radiation Oncology
Plesmanlaan 121
1066 CX Amsterdam
The Netherlands
T 31 20 5122124
F 31 20 6691101

Surgery

Prof. C. van de Velde MD PhD (LUMC)
C.J.H.van_de_Velde@lumc.nl
Leiden University Medical Center
Department of Surgery
PO Box 9600
2300 RC Leiden
The Netherlands
phone: +31 71 5262309
fax +31 71 5266750

Gastroenterology/ Medical oncology

H. Boot MD PhD
h.boot@nki.nl
The Netherlands Cancer Institute/
Antoni van Leeuwenhoek Hospital
Department of Gastroenterology and Hepatology
Plesmanlaan 121
1066 CX Amsterdam
The Netherlands
phone: +31 20 512 2566
fax: +31 20 512 2572

A. Cats MD PhD
a.cats@nki.nl
The Netherlands Cancer Institute/
Antoni van Leeuwenhoek Hospital
Department of Gastroenterology and Hepatology
Plesmanlaan 121
1066 CX Amsterdam
The Netherlands
phone: +31 20 512 2566
fax: +31 20 512 2572

Pathology

Prof. G.A. Meijer MD PhD
ga.meijer@vumc.nl
VU University Medical Center
Department of Pathology
PO Box 7057
1007 MB Amsterdam
Phone: +31 20 4444852
Fax: +31 20 4442964

Quality of life

Prof. N.K. Aaronson, Ph.D.
n.aaronson@nki.nl
The Netherlands Cancer Institute/
Antoni van Leeuwenhoek Hospital
Division of Psychosocial Research & Epidemiology
Plesmanlaan 121
1066 CX Amsterdam
The Netherlands
phone: +31 20 512 2481
fax: +31 20 512 2322

Statistics

H. Putter PhD
h.putter@lumc.nl
Leiden University Medical Centre
Dept of Medical Statistics
PO Box 9600
2300 RC Leiden
The Netherlands
phone: +31(0) 71-5269705
fax: +31(0) 71-5276799

Datamanagement

E. Meershoek – Klein Kranenburg MSc
datacenter@lumc.nl
Leiden University Medical Centre
Datacenter Heelkunde, K-6-R
PO Box 9600
2300 RC Leiden
The Netherlands
phone: +31(0) 71-526 3500
fax: +31(0)71-526 6744

EudraCT number:

2006-004130-32

Contents	Page
1. Summary	5
2. Introduction	6
3. Objectives and endpoints of the study	11
4. Study Methods	12
5. Study Scheme	12
6. Patient Selection	13
7. Baseline investigations	14
Flow charts	15
8. Treatment	
A) Chemotherapy	17
B) Surgery	24
C) Radiotherapy	32
D) Pathology	35
9. Adverse events and scoring of toxicity	38
10. Side studies	39
11. Quality of life study	41
12. Statistics	42
13. Ethics	44
14. Randomisation. data management and analysis	44
15. Publication	48
16. References	49
17. Addenda	
A. Patient information and informed consent form (Dutch)	52
B. WHO classification	69
C. EORTC Quality of Life questionnaire QLQ-ST022 and QLQ-C30	70
D. CTC grading	73
E. Dose calculations capecitabine	74
F. Collection of biopsies by optional gastroscopy	75
G. Collection of blood for translational research	78

1. SUMMARY

Background: The mainstay of curative treatment of gastric cancer is radical surgical dissection. Because most patients in the Western world present with advanced stages long term survival is found in about 25%, with local recurrences as part of treatment failure in up to 80% of cases. Studies examining the role of more extended lymph node dissections (D1 vs. D2), adjuvant radiotherapy or adjuvant chemotherapy did not result in a clinical relevant improvement of survival. In 2001 results of a South West Oncology group (SWOG) trial that randomized between surgery and surgery with chemoradiotherapy were published. This trial, that was hampered by suboptimal surgery (less than D1 in majority of patients) and radiotherapy (2D radiotherapy; 35% protocol deviations) showed an absolute increase in median survival of 9 months. More recently results of the MAGIC study, which randomized between surgery and surgery plus 6 perioperative courses of ECF chemotherapy, were presented. This regimen resulted in an absolute 5-year survival benefit of 13% and in a 10% higher resectability rate.

Objectives: This study investigates whether chemoradiotherapy (45 Gy in 5 weeks with weekly cisplatin and daily capecitabine) after preoperative chemotherapy (3x ECC (epirubicin, cisplatin, capecitabine)) and adequate (D1+) surgery leads to improved survival in comparison with postoperative chemotherapy (3x ECC). Furthermore, toxicity of both treatment regimens will be explored.

Methods: Phase III prospectively randomized trial

Endpoints: primary: overall survival (OS); secondary: disease-free survival (DFS), toxicity and health-related quality of life (HRQL) and prediction of response and recurrence risk assessed by genomic and proteomic profiling.

Patient selection: Ib-IVa(M0) operable gastric cancer; WHO \leq 2; age > 18 yrs; hematology, electrolytes, liver and renal tests within normal range; no prior radio- or chemotherapy that influences treatment for gastric cancer; renography findings that allow upper abdominal radiotherapy; written informed consent.

Statistics: With an expected 5 year OS of 40% in the observational arm (chemo-surgery-chemo) and an expected 5 year OS of 50% in the experimental arm, an accrual time of 4 years and a follow up time of 3 years, **788** patients would be required to achieve 80% power to detect this difference at a significance level of 0.05, allowing for 10% loss to follow-up. This is feasible with a yearly accrual of 197 patients per year.

Expected results: With optimal chemotherapy, adequate surgery and 3D conformal radiotherapy a 10% absolute improvement in overall and disease-free survival is expected with manageable toxicity.

Relevance for the Dutch Cancer Society: Worldwide gastric cancer is the second most diagnosed malignancy and in Europe it is the third most cause of cancer mortality. For the Dutch Cancer Society it would be of great relevance to investigate whether innovations in the three large oncology disciplines, surgery, medical oncology and radiotherapy, when combined optimally in one treatment regimen, could improve the outlook for gastric cancer patients.

2. INTRODUCTION AND BACKGROUND

Radical surgical dissection of gastric cancer is the basis of cure in this disease. However, because most patients in the Western world present with advanced stages, surgery alone provides long-term survival in only 20-30% of patients. Western series report locoregional failures in about 60% of patients with positive lymph nodes or involvement of the serosa. (1;2) This high relapse rate has initiated a whole spectrum of more aggressive treatments which did not result in favorable survival until the introduction of combined chemoradiation in the adjuvant setting. (3)

First of all, a few prospective randomized trials, have investigated the role of more extensive lymph node dissection (D2) in comparison with the standard D1 lymph node dissection in which only the perigastric nodes are removed. In the Dutch Gastric Cancer Group trial 711 patients that were treated with curative intent were randomized between D1 and D2 lymph node dissection. After a median follow up of 11 years there was no survival difference (30 vs. 35%; $p = 0.53$). Morbidity (25 vs. 43%; $p < 0.001$) and mortality (4 vs. 10%; $p = 0.004$) however, were significantly higher in the D2 group. (4) In the British MRC trial 400 gastric cancer patients were also prospectively randomized between D1 and D2 lymph node dissection. (5) Five year survival was 35% in the D1 and 33% in the D2 group; morbidity was 28% and 46% respectively, mortality was 6.5% for D1 and 13% in D2. Since these two trials were published a lot of debate has been generated about two topics. First of all, since subgroup analyses have indicated a trend for better survival in N2 patients after a D2 dissection, the question has risen whether there is a role for D2 resections in this subset of patients. Furthermore, there is considerable debate about the role of routine splenectomy and resection of the pancreatic tail in order to facilitate a D2 resection. It is hypothesized that in performing a D1 dissection without splenectomy and resection of the pancreatic tail, together with dissection of at least 15 (N1 and N2) nodes, a so-called D1 over (D1+) resection, can result in better outcome. (6;7)

Adjuvant radiotherapy in operable gastric cancer has also failed to improve treatment results. In the British Stomach Cancer group 436 patients were randomized between surgery only and surgery with 45-50 Gy radiotherapy or surgery with FAM chemotherapy. (8) After 5 years of follow up there was no survival difference between the 3 arms.

Many studies have been performed with adjuvant chemotherapy in operable gastric cancer. These studies have been part of several meta-analyses, which could demonstrate no, or at the most a modest survival benefit for adjuvant chemotherapy. (9-13) The majority of the chemotherapy regimens used in these studies are regarded as old fashioned nowadays and therefore until recently adjuvant chemotherapy had no place in the standard treatment of operable gastric cancer.

In 2005 final results of the MAGIC-study on perioperative chemotherapy have been presented. (14) In this large multicenter study patients were randomized between surgery only and 3 cycles preoperative ECF (epirubicin, cisplatin, 5-FU) followed by surgery and then another 3 cycles of

ECF chemotherapy. This regimen resulted in a 10% higher resectability rate and a significant survival benefit of 13% (23% vs. 36% at 5 years). It should be noted that 80% underwent surgical resection, and that 66% of the patients commenced the postoperative chemotherapy and 42% completed the entire treatment. In addition, 50% of patients who completed preoperative chemotherapy and surgery, also completed postoperative treatment. The main reason (70% of the patients) for not starting postoperative chemotherapy was disease progression or patient choice (Cunningham ASCO GI 2006). Despite this disappointing number of patients undergoing systemic treatment, perioperative chemotherapy with ECF may be considered as a new standard of treatment in operable gastric cancer.

In a Cochrane review of randomized trials in advanced gastric cancer highest survival rates were achieved with anthracyclines, cisplatin and 5-FU, both independently and in combination (Cochrane Library, 2005). Within these combinations ECF proved to be tolerated best. However, the use of continuous infusional 5-FU is considered cumbersome, because it requires the implantation of central venous catheter devices and the use of portable infusion pumps, which are associated with complications such as thrombosis and wound infection. Capecitabine, a prodrug and oral analogue of 5-FU, is believed to mimic continuous infusion of 5-FU and has demonstrated to be at least equally effective in tumor control and to be less toxic than intravenous 5-FU in patients with stage III and IV colon cancer.(15-17) In a pharmacokinetic phase I study in patients with advanced oesophagogastric cancer, the recommended dose of capecitabine in combination with epirubicin and cisplatin was 1000 mg/m² bid.(18) The regimen proved to be highly effective in a phase II study in 54 Korean patients with advanced gastric cancer with an objective response rate of 59% and mild toxicity (neutropenic fever in 5% and grade 3/4 vomiting in 9%).(19) A currently ongoing large randomized multicentre phase III study (REAL 2) is evaluating the potential roles of oxaliplatin (instead of cisplatin) and capecitabine (instead of 5-FU) in this schedule. The dose of capecitabine administration was escalated from 500 to 625 mg/m² bid after the first planned interim analysis. The preliminary results suggest that the replacement of 5-FU by capecitabine (and of cisplatin by oxaliplatin) is safe and does not impair efficacy.(20) Final results are awaited for and will be available at ASCO 2006. Meanwhile the combination of epirubicin, cisplatin and capecitabine seems appropriate as perioperative chemotherapy in operable gastric cancer.

In 2001, with the introduction of postoperative combined chemoradiotherapy for the first time a substantial improvement in survival and locoregional control has been described. In the SWOG/ Intergroup 0116 trial 556 patients were prospectively randomized between surgery only and surgery plus postoperative chemoradiotherapy. (21) Radiotherapy consisted of 45 Gy in 25 fractions in five weeks. The chemotherapy regimen consisted of three cycles of 5-fluorouracil and leucovorin according to the Mayo regimen perioperatively and two shortened courses during radiotherapy. An impressive increase in median overall survival was obtained in the chemoradiotherapy group; 36 months versus 27 months in the surgery only group. Furthermore relapse free survival was prolonged from 19 months in the surgery only arm to 30 months in the

chemoradiotherapy arm. It was thus shown that in gastric cancer too, the advantage in combining modalities is the ability to address both locoregional and systemic disease simultaneously. This postoperative chemoradiotherapy regimen has become standard treatment in the US; nevertheless this study has been criticized because of suboptimal surgery, concerns about toxicity, an outdated chemotherapy regimen and suboptimal radiotherapy techniques. Indeed, 54% of all patients underwent a D0 lymph node dissection, which in it self could be one factor in undermining survival. (22) Furthermore, patients in both arms were at higher risk for relapse than most surgical series published: more than two thirds had T3 or T4 tumors and 85% had lymph node metastasis. In addition, toxicity in the chemoradiotherapy arm was substantial. Grade III/IV haematological and gastrointestinal toxicity was encountered in 54% and 33% of patients respectively, and consequently only 64% of patients managed to complete the planned treatment. Since the SWOG/Intergroup study was initiated at the beginning of the 90's, nowadays the concept of concurrent chemoradiotherapy is more crystallized. Studies in other solid tumors like non small cell lung cancer, head and neck cancer, cancer of the uterine cervix, esophageal and anal cancer have shown that intensive concurrent chemoradiotherapy in comparison with radiotherapy only can improve outcome when used as (neo)adjuvant treatment and/or can prolong (relapse free) survival. (23-27) Especially regimens in which patients are exposed to radiation and radiosensitizing chemotherapy (cisplatin) daily, seem to have a beneficial effect. Cisplatin and 5-FU are extensively used and effective drugs in the treatment of gastrointestinal malignancies. Mechanisms of synergy between radiation and cisplatin and 5-FU have been well described. Cisplatin inhibits repair of radiation injury and directly enhances DNA injury of the initial radiation by the formation of DNA adducts as well. It is believed that radiotherapy sensitizes the cell to the DNA interfering effect of 5-FU. Because cell survival studies indicate that the greatest synergy is obtained if 5-FU concentrations are maintained at high levels for at least 24 hours after radiation therapy, it seems appropriate to administer 5-FU using continuous infusional rather than bolus schedules. (28;29) Capecitabine, a prodrug and oral analogue of 5-FU is believed to mimic continuous infusion of 5-FU and has demonstrated to be at least equally effective in tumor control and to be less toxic than intravenous 5-FU in patients with stage III and IV colon cancer.(15-17) In several phase I/II studies capecitabine concurrently with radiation appears to be feasible in the treatment of locally advanced rectal cancer.(30) Vaishampayan et al. have described concurrent capecitabine and radiation in gastrointestinal malignancies, in the post- as well as preoperative setting. (31) The median dose of capecitabine was 1600 mg/m²/day orally for 5 days a week during the complete radiation treatment, while radiation doses were in the range of 45-64 Gy in fractions of 1.8 Gy. Grade III and IV toxicity were seen in 7 of 32 patients (neutropenia (3); thrombocytopenia (1); diarrhea (1); myocardial infarction (1) and asthenia (1)). The disadvantage of concurrent chemoradiation therapy is its increased acute and chronic toxicity. In gastric cancer, dose limiting organs in the radiation fields are the remnant stomach, small intestine, spinal cord, kidneys and liver. Kollmannsberger et al. have reported two phase II studies that evaluated postoperative adjuvant chemotherapy (leucovorin, 5-FU, cisplatin with or

without paclitaxel) combined with 5-FU based chemoradiotherapy.(32) Eighty-six patients were included, of which 95% had at least a D1 resection. Both chemotherapy regimens appeared to be feasible and had acceptable toxicity that consisted mainly of anorexia and weight loss, of which a substantial part was seen during chemoradiotherapy and the post-chemoradiotherapy courses. Recently, we have finished a phase I-II trial in which a fixed radiotherapy regimen (45 Gy in 25 fractions) that was combined concurrently with escalating doses of cisplatin (iv) and capecitabine (oral) in patients that had curative surgery for gastric cancer. (Jansen et al. Proc Am Soc Ther Rad Oncol 2005) In this study of 24 patients the maximal tolerable dose (MTD) was 650 mg/m² capecitabine bid and 5 mg/m² cisplatin daily. Dose limiting toxicity was neutropenia grade III (1 patient) and thrombocytopenia grade III (1 patient). Because daily administration of cisplatin (i.v.) is logistically cumbersome for patients and institutions, we also explored the weekly application of cisplatin together with daily radiotherapy and capecitabine. In a dose escalation study, cisplatin in a weekly dose of 25 mg/m² in 6 patients resulted in 2 DLT's (grade III weight loss and neutropenia) . With a weekly dose of 20 mg/m², chemoradiotherapy was feasible (results of this study will be submitted to the ASCO-GI conference 2008). The final dose level for the current study will therefore be cisplatin 20 mg/m² and capecitabine 575 mg/m² bid. In the majority of these patients 3D conformal CT-based radiotherapy techniques were used, with maximal sparing of dose limiting structures (kidneys) but with adequate coverage of the *clinical target volume*. With respect to late toxicity, the kidneys are the dose-limiting organs. We and others have previously shown in gastric lymphoma that radiation induces a dose- and volume-dependent decrease in renal function which continues to decline over time and is associated with an enhanced risk of developing (renovascular) hypertension (33). In the abovementioned phase I-II study we have specifically addressed renal toxicity in a prospective fashion. In 44 patients the relative contribution of the left kidney to the total renal function was reduced by 15% at 1 year and 50% at 2 years (Verheij et al. Proc Am Soc Ther Rad Oncol 2005). These findings illustrate the need for more sophisticated and precise radiotherapy techniques (e.g. 3D-conformal, IMRT) in order to minimize renal toxicity.

Taken the abovementioned pivotal MAGIC and SWOG/Intergroup studies together, the important question that needs to be answered is whether postoperative chemoradiotherapy improves survival and/or locoregional control in patients that receive neoadjuvant chemotherapy followed by a D1+ gastric resection. We therefore propose to conduct a prospective randomized multicenter phase III trial addressing this important question. To ascertain patient compliance and improve patient selection/ treatment tailoring, we plan to incorporate validated prognostic and predictive tests, such as Maruyama Index and nomogram for gastric cancer. (34;35) In the chemoradiotherapy arm state-of-the-art 3D-conformal or Intensity-Modulated RadioTherapy (IMRT) should be a minimal requirement in order to limit normal tissue toxicity, in particular kidney damage. Quality of life will be compared between both treatment arms, using the EORTC QLQ-STO22 QLQ-C30 questionnaires. The chemotherapy schedule in both arms should be effective

and safe. The combination of epirubicin, cisplatin and capecitabine fulfils these requirements. An optimized chemoradiotherapy schedule with radiosensitizing drugs during the entire radiotherapy treatment has been established with daily cisplatin and capecitabine in our phase I-II study.

- Therefore, the following study design is proposed: A phase III study which randomizes between preoperative chemotherapy (3 courses of epirubicin, cisplatin and capecitabine (ECC)) and D1+ gastric surgery followed by postoperative chemotherapy (another 3 courses of ECC) or chemoradiotherapy. Chemoradiotherapy consists of 45 Gy radiotherapy in 25 fractions with concurrent capecitabine and cisplatin

3. Objectives and aims of the study

Primary endpoints

- To assess whether postoperative chemoradiotherapy prolongs overall survival compared to postoperative chemotherapy in patients that have had adequate stomach surgery following preoperative chemotherapy

Secondary endpoints

- To assess whether postoperative chemoradiotherapy prolongs disease free survival compared to postoperative chemotherapy in patients that have had adequate stomach surgery following preoperative chemotherapy
- To assess the toxicity profile of both preoperative and postoperative chemotherapy and postoperative chemoradiotherapy
- To collect tissue and serum for genomic profiling and proteomics to detect tumor recurrence risk patterns in gastric cancer
- To determine a genomic profile and classifier to predict response to therapy
- To assess the value of Maruyama-index and predictive nomograms for disease recurrence (36;37)
- To compare health-related quality of life (HRQL) of both treatment regimens

4. STUDY METHODS

Phase III prospective randomized multicenter study

After randomization all patients will receive 3 courses of ECC chemotherapy. 3-6 weeks after the last course all patients (if there are no signs of progressive disease or other contraindications for surgery) proceed to surgery.

Patients that are in the observation arm will receive 3 additional ECC courses after surgery within 4-12 weeks after surgery.

Patients that are in the experimental arm will start chemoradiotherapy within 4-12 weeks after surgery.

5. RANDOMIZATION SCHEME:

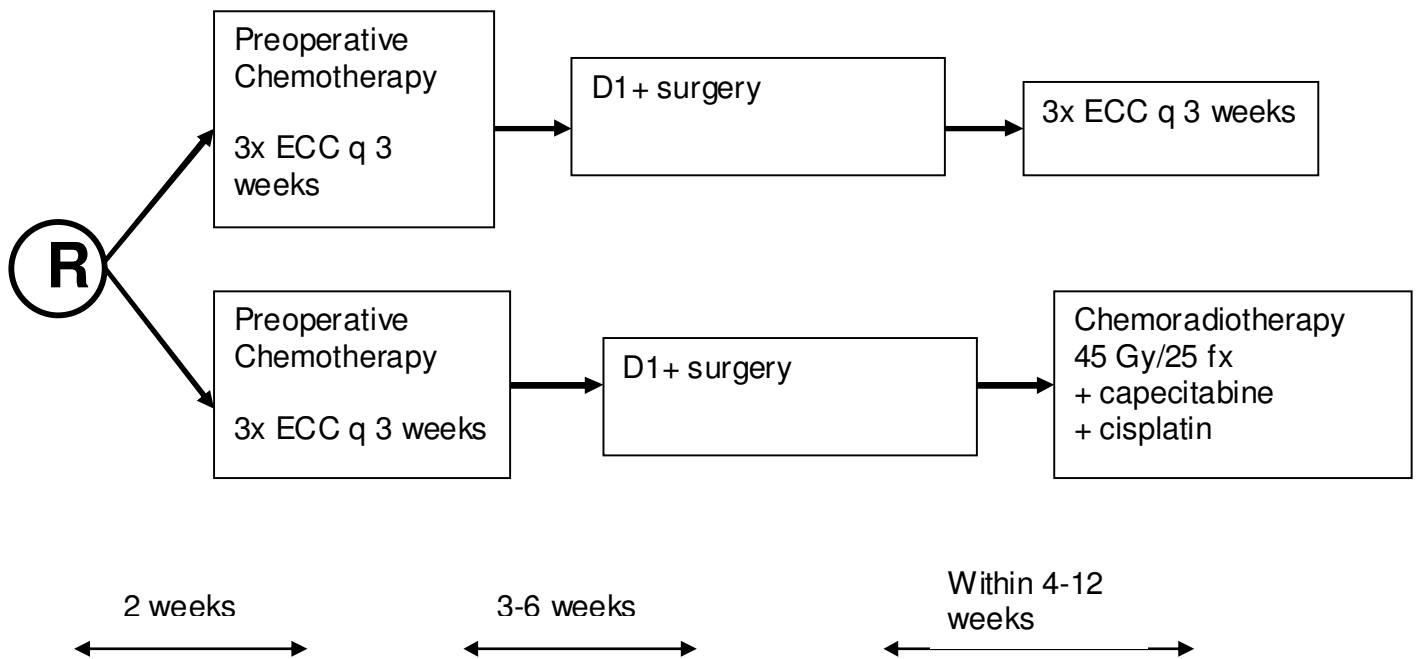

STRATIFICATION WILL BE DONE WITH THE FOLLOWING PARAMETERS:

- HISTOLOGICAL TYPE (Lauren classification): intestinal or diffuse type or mixed
- LOCALISATION OF TUMOR: GE-junction, proximal or distal gastric
- HOSPITAL

6. PATIENT SELECTION

Inclusion criteria

- Ib-IVa (no distant metastases) gastric cancer (histologically proven); tumor bulk has to be in the stomach but may involve gastro-esophageal junction
- WHO < 2
- age ≥18 yrs
- Operable gastric cancer
- No prior abdominal radiotherapy or chemotherapy
- Hematology: Hb ≥ 5.0 mmol/l; leukocytes ≥ 3.0x10⁹/l, neutrophils ≥ 1.5x10⁹/l, thrombocytes ≥ 100 x 10⁹/l
- Renal function: serum creatinine ≤ 1.25 ULN, creatinine clearance ≥ 60 ml/min (measured, or calculated by Cockcroft and Gault formula) and urinary excretion of ≤ 1.0 gram protein/24 hours
- Liver function: total bilirubin ≤1.5x ULN, Alkaline phosphatase and ASAT/ALAT ≤ 3x ULN
- Left ventricular ejection fraction > 50%
- Tumornegative laparoscopy when CT suggests peritoneal carcinomatosis
- Start treatment within 10 working days after registration
- Written informed consent
- Expected adequacy of follow-up

Exclusion criteria

- T1N0 disease (endoscopic ultrasound)
- Distant metastases
- Inoperable patients; due to technical surgery-related factors or general condition
- Previous malignancy, except adequately treated non-melanoma skin cancer or in-situ cancer of the cervix uteri.
- Solitary functioning kidney that will be within the radiation field
- Major surgery within 4 weeks prior to study treatment start, or lack of complete recovery from the effects of major surgery
- Uncontrolled (bacterial) infections
- Significant concomitant diseases preventing the safe administration of study drugs or likely to interfere with study assessments
- Uncontrolled angina pectoris; cardiac failure or clinically significant arrhythmias
- Continuous use of immunosuppressive agents
- Concurrent use of the antiviral agent sorivudine or chemically related analogues, such as brivudine
- Hearing loss > CTC grade 1
- Neurotoxicity > CTC grade 1
- Pregnancy or breast feeding
- Patients (M/F) with reproductive potential not implementing adequate contraceptive measures

7. BASELINE INVESTIGATIONS

Required baseline investigations before start treatment (to be performed within 28 days before randomization)

History and physical examination

- Weight, length, performance status (WHO)

Oesofagogastroduodenoscopy

- representative tumor biopsy samples
- tissue sampling for biobanking purposes to secure adequate material before the start of therapy
- in case of malnutrition placement of feeding tube

Endoscopic Ultrasonography (Optional)

Advocated if stage Ia disease (T1N0) is suspected. If this is confirmed the patient should not be entered into the study

Laboratory

- Hemoglobin, WBC and neutrophils, platelets
- Creatinine and creatinine clearance (measured or calculated), Na, K, Ca, P
- Bilirubin, Alk.phosphatase, ASAT, ALAT, γ GT, LDH
- Albumin
- Tumomarkers: CEA, CA 19.9
- 24-hours urine collection for protein and optional creatinine clearance

X-rays, scans etc

- Chest X-ray
- CT-scan chest and abdomen
- Renography
- Cardiac ejection fraction by MUGA-scan or equivalent
- PET (optional)

Other

- In case of suspicion of peritonitis ► diagnostic laparoscopy
- EKG
- Caloric intake \geq 1500 kcal/day, verified by a dietician before registration; if caloric intake is $<$ 1500 kcal/day nasogastric feeding tubes or jejunostomy should be considered;
- **Insertion of a jejunostomy during surgery is strongly recommended, it should be left *in situ* until the postoperative treatment is finished**
- Central pathological review of the gastrectomy specimen

Required studies during treatment and follow up. Chemotherapy-surgery-chemotherapy arm

Required Studies	Pre-study								Wk 4	Wk 8	Mnth 3	Mnth 6	Mnth 9	Mnth 12	Mnthq 6 m until 5 yrs
Treatment		ECC 1	ECC 2	ECC 3	Surg	ECC 4	ECC 5	ECC 6							
Physical															
History/ Ph.Ex	X	X	X	X	X	X	X	X	X	X	X	X	X	X	
Consult Rad. Oncol															
Consult Gastro- enterologist/med oncologist	X	X	X	X		X	X	X	X	X	X	X	X	X	X
Consult Surgeon	X				X				X		X				X
Weight/PS	X	X	X	X	X	X	X	X	X	X	X	X	X	X	X
Toxicity	X	X	X	X	X	X	X	X	X	X	X				
Dietician	X			X	X	X				X		X			
Laboratory															
Hematology	X	X	X	X	X	X	X	X	X	X	X	X	X	X	
sCreatinine	X	X	X	X	X	X	X	X		X		X		X	X
Liver tests; Albumin	X	X	X	X	X	X	X	X		X		X		X	
CEA, CA 19.9	X			X					X		X	X	X	X	X
X-rays/scan															
Chest x-ray	X								X					X	
Ejection fraction	X								X						
CT Abd-Chest	X			X					X			X		X	X (6-monthly)
Renography	X											X		X	X (yearly)
Esophagogastroduode noscopy (EGD)	X														
PET-scan (optional)	X								X						
Other: serum for proteomics EKG, review histology, Urine analysis HRQL QLQ-C30 + QLQ-STO22	X														
	X					X			X					X	

Required studies during treatment and follow up. **Chemotherapy-surgery-chemoradiotherapy arm**

Required Studies	Pre-study				Wk	Wk	Wk	Wk	Wk	Wk		Wk 4	Wk 8	Mnth 3	Mnth 6	Mnth 9	Mnth 12	Mnth q 6 m until 5 yrs
Treatment RT=radiotherapy Pt=cisplatin Cap=capecitabine		ECC 1	ECC 2	ECC 3	Surg	RT Pt Cap	RT Pt Cap	RT Pt Cap	RT Pt Cap	RT Pt Cap								
Physical																		
History/ Ph.Ex	X	X	X	X	X	X	X	X	X	X		X	X	X	X	X	X	
Consult Rad. Oncol	X					X	X	X	X	X		X	X		X		X	X
Consult Gastro-enterologist/med oncologist	X	X	X	X		X	X	X	X	X		X		X		X		X
Consult Surgeon	X				X							X		X				X
Weight/PS	X	X	X	X	X	X	X	X	X	X		X	X	X	X	X	X	X
Toxicity	X	X	X	X	X	X	X	X	X	X		X	X	X				
Dietician	X			X	X	X		X		X			X		X			
Laboratory																		
Hematology	X	X	X	X	X	X	X	X	X	X		X	X	X	X	X	X	
sCreatinine	X	X	X	X	X	X	X	X	X	X			X		X		X	X
Liver tests; Albumin	X	X	X	X	X	X		X	X	X			X		X		X	
CEA, CA 19.9	X			X								X	X	X	X	X	X	X
X-rays/scan																		
Chest x-ray	X											X					X	
Ejection fraction	X											X						
CT Abd-Chest	X			X								X			X		X	X (6-MONTHLY)
Renography	X														X		X	X (YEARLY)
Esophagogastroduodenoscopy (EGD)	X																	
PET-scan (optional)	X											X						
Other: serum for proteomics EKG, review histology, Urine analysis	X																	
HRQL QLQ-C30 + QLQ-STO22	X					X						X					X	

8. TREATMENT

A) Chemotherapy

Pre- and postoperative chemotherapy

Chemotherapy regimen

All patients will receive 3 cycles of ECC at three-weekly intervals preoperatively. This treatment will start within 10 working days after registration. Patients randomized to receive the standard arm will also receive 3 cycles of ECC postoperatively. This treatment should restart between 4 and 12 weeks after surgery.

The chemotherapy regimen:

Epirubicin will be given in a dose of 50 mg/m^2 on day 1 as an intravenous push every 3 weeks immediate prior to the cisplatin.

Cisplatin will be administered at a dose of 60 mg/m^2 on day 1 intravenously every 3 weeks with hydration according to local practice.

Capecitabine will be given orally in two equally divided doses, $1000 \text{ mg/m}^2 \text{ bid}$ with a meal or snack from day 1-14 every 3 weeks. Tablets are 500 mg and 150 mg respectively and the doses should be adjusted so that whole tablets can be taken.

Scheme for chemotherapy administration

Hydration can be done according to local practice, however, the following schedule is recommended.

Day	Time	
1	evening	Prehydration: 1000 ml NaCl 0,45/glucose 2,5%
2	8:00-12:00	1000 ml NaCl 0,45/glucose 2,5% Start capecitabine within 30 min after breakfast Epirubicin can be given any time during this period
	12:00-16:00	1000 ml 0,9% NaCl + cisplatin
	16:00-20:00	1000 ml NaCl 0,45/glucose 2,5% + 20 mmol KCl 500 mg MgSO ₄ + 1000 mg calciumgluconaat (2.25 mmol added to 100 ml 0.9% NaCl in 15 min)
	20:00-2:00	1000 ml NaCl 0,45/glucose 2,5% + 20 mmol KCl 500 mg MgSO ₄ + 1000 mg calciumgluconaat (2.25 mmol added to 100 ml 0.9% NaCl in 15 min)
	2:00-8:00	1000 ml NaCl 0,45/glucose 2,5% + 20 mmol KCl 500 mg MgSO ₄ + 1000 mg calciumgluconaat (2.25 mmol added to 100 ml 0.9% NaCl in 15 min)
3	8:00	Check fluid balance and administer low dose furosemide (10mg) if necessary because of significant weight gain

For accurate capecitabine dose calculations according to BSA see addendum 5.

The following table can be used to prescribe the correct dose and number of tablets

For capecitabine $1000 \text{ mg/m}^2 \text{ bid}$ (100% dose level)

BSA	Total daily dose	Tablets/day	Tablets/day	Total tablets	Total tablets	Prescription	Prescription
		150 mg	500 mg	for 14 days 150 mg	for 14 days 500 mg	Morning + evening 150 mg	Morning + evening 500 mg
≤1,22	2300	2	4	28	56	1+1	2+2
1,23 - 1,40	2600	4	4	56	56	2+2	2+2
1,41 - 1,57	3000	0	6	0	84	0	3+3
1,58 - 1,72	3300	2	6	28	84	1+1	3+3
1,73 - 1,90	3600	4	6	56	84	2+2	3+3
≥ 1,91	4000	0	8	0	112	0	4+4

Supportive measures during chemotherapy

A suggested regimen for administration of anti-emetics is:

Dexamethasone 10 mg iv at time zero

Granisetron 1 mg iv bid starting at time zero, for 2 days

Metoclopramide 10 mg tid, orally on demand starting at day 3 until necessary

Alternative schedules may be employed if preferred.

Toxicity

The toxic features of the individual agents are outlined below:

- Epirubicin: nausea, vomiting, myelosuppression, alopecia, myocardial dysfunction
- Cisplatin: nausea, vomiting, renal toxicity, peripheral neuropathy, ototoxicity, myelosuppression
- Capecitabine: hand-foot syndrome, stomatitis, nausea, diarrhea, myelosuppression

Dose modification

Epirubicin:

When the left ventricular ejection fraction is 50% or more, the full dose of epirubicin will be given.

Cisplatin:

Creatinine clearance (measured, or calculated by Cockcroft and Gault formula) prior to treatment should be more than 60 ml/min. Thereafter creatine clearance should be repeated before each course of cisplatin and its dose should be adjusted as follows:

Creatinine clearance

> 60 ml/min Full dose

40-60 ml/min Same dose of cisplatin in mg as the value off creatinine clearance in ml/min
(for example of 45 ml/min give 45 mg/m² cisplatin)

< 40 ml/min Omit cisplatin

Patients developing significant ototoxicity or sensory neurotoxicity should have the cisplatin discontinued.

Capecitabine

Hand-foot syndrome

If painful swelling or erythema of hands occur, emollients are beneficial. Pyridoxin (vitamin B6) 50-300 mg/day has been reported to be of possible benefit to the patients. Pyridoxin is not licensed for this indication. In case of hand-foot syndrome it is allowed to administer pyridoxine. However, prophylactic use of pyridoxine is not allowed in this study. In case of hand-foot syndrome grade ≥ 2, dosing should be interrupted until recovery ≤ grade 1. The omitted doses should not be administered afterwards or exceeding 14 days. When toxicity does not improve capecitabine will be discontinued for one week and restarted after a reduction of the dose with 25%.

Diarrhea Grade 1 diarrhea will be treated with loperamide or codeine phosphate. In case of diarrhea grade 2-4, capecitabine should be interrupted immediately and should only be restarted when diarrhea has resolved. If diarrhea persists for more than 48 hours despite recommended loperamide and codeine phosphate treatment, patients should be hospitalized for parenteral support and anti-diarrheal treatment (e.g. octreotide, tinctura opii).

Capecitabine dose modifications for non-haematological toxicity:

In case of a second episode of grade 2 or first episode of grade 3 toxicity, capecitabine should be restarted after a 25% dose reduction. In case of a second episode of grade 3 or first episode of 4 toxicity, capecitabine should be restarted after a 50% dose reduction. If toxicity recurs hereafter capecitabine should be discontinued.

Myelosuppression

Use worse CTC grade for either ANC or WBC

ANC	WBC	CTC grade	Dosing
≥ 2,0	≥ 4,0	0	Full dose
1,5 - 1,9	3,0 - 3,9	1	Full dose
1,0 - 1,4	2,0 - 2,9	2	Full dose
0,5 - 0,9	1,0 - 1,9	3	Delay epirubicin, cisplatin and capecitabine with 1 week until recovery. Then restart capecitabine and cisplatin full dose and reduce epirubicin by 25% on subsequent cycles
< 0,5	< 1,0	4	Delay epirubicin, cisplatin and capecitabine with 1 week until recovery. Then restart capecitabine and cisplatin full dose and reduce epirubicin by 50% on subsequent cycles

In case of neutropenic fever delay epirubicin, cisplatin and capecitabine until recovery. Then restart capecitabine and cisplatin full dose and reduce epirubicin by 25% on subsequent cycles.

Platelets	CTC grade	Dosing
≥ 100	0	Full dose
75 - 99	1	Delay 1 week and restart full dose
50 - 74	2	Delay epirubicin, cisplatin and capecitabine with 1 week until recovery. Then restart capecitabine and cisplatin full dose and reduce epirubicin by 25% on subsequent cycles
25 - 49	3	Delay epirubicin, cisplatin and capecitabine with 1 week until recovery. Then restart capecitabine and cisplatin full dose and reduce epirubicin by 50% on subsequent cycles
< 25	4	Delay cisplatin and capecitabine with 1 week until recovery. Then restart capecitabine and cisplatin full dose and omit epirubicin from subsequent cycles

In case of difficulties with the ingestion of capecitabine

In case of difficulties with the ingestion of capecitabine, capecitabine may be replaced by 5-FU by continuous infusion 200 mg/m² daily for 21 days, starting at day 1. For this purpose implantation of a central venous catheter device and the use of a portable infusion pump are necessary. The selection of such a central venous catheter device and portable infusion pump is considered to be a local decision, as is the way complications like thrombosis and infections are prevented.

In the Netherlands Cancer Institute/ Antoni van Leeuwenhoek Hospital a Port-a-Cath® device is inserted in the left (or right) subclavian vein in combination with a re-usable portable battery powered CADD 1 pump. The 5-FU is administered in a syringe with 80 ml 0.9% NaCl with 200 mg/m² for 8 days and 5000 IU of heparin. The syringe is subsequently changed on a weekly basis (leaving 5-FU for one day in the syringe). At that time Hb, WBC, ANC and thrombocytes should be checked as well. 5-FU should be discontinued in case of grade 2 toxicity during the chemotherapy cycles. At the start of each cycle the recommendations for capecitabine as described above account for 5-FU as well.

Chemotherapy as part of concurrent chemoradiotherapy (experimental arm)

The combined chemoradiotherapy regimen:

Capecitabine will be given in two equally divided doses, 575 mg/m² bid, with a meal or snack from Monday till Friday during 5 weeks. During weekend days without radiotherapy, no capecitabine will be administered. Tablets are 500 mg and 150 mg respectively and the doses should be adjusted so that whole tablets can be taken. Capecitabine should be taken within 6 hours prior to radiotherapy.

Cisplatin will be administered at a dose of 20 mg/m² intravenously with pre- and posthydration once weekly during 5 weeks (days 1, 8, 15, 22 and 29). For pre- and posthydration schedule see abovementioned suggested schedule. .

Radiotherapy 45 Gy in 25 fractions will be administered from Monday till Friday during 5 weeks. During weekend days no radiotherapy will be administered.

In case of limited capability of intake of fluids (< 1500 ml/day) or reduced urine production, additional saline infusion is recommended.

Treatment schedule:

Day	1-5	8-12	15-19	22-26	29-33
Treatment					
<i>Chemotherapy</i>					
Cisplatin	+	+	+	+	+
Capecitabine	+++++	+++++	+++++	+++++	+++++
<i>Radiotherapy</i>	+++++	+++++	+++++	+++++	+++++

The following table can be used to prescribe the correct dose and number of tablets for **capecitabine 575 mg/m² bid**

BSA	Total daily dose	Tablets/day 150 mg	Tablets/day 500 mg	Total tablets for 5 weeks 150 mg	Total tablets for 5 weeks 500 mg	Prescription Morning + evening 150 mg	Prescription Morning + evening 500 mg
≤1,37	1600	4	2	100	50	2+2	1+1
1,38 - 1,72	2000	0	4	0	100	0	2+2
≥ 1,73	2300	2	4	50	100	1+1	2+2

Supportive measures during chemoradiotherapy

A suggested regimen for administration of anti-emetics is:

Metoclopramide 10 mg tid, orally on demand

In case of failure:

Granisetron 1 mg od iv or orally, in combination with MgO

Alternative schedules may be employed if preferred.

Toxicity

Toxicity will be measured according to NCI Common Toxicity Criteria, version 3.0.

The toxic features of the individual agents are outlined below:

Cisplatin: anorexia, nausea, vomiting, weight loss, renal toxicity, peripheral neuropathy, ototoxicity, myelosuppression

Capecitabine: hand-foot syndrome, stomatitis, anorexia, nausea, weight loss, diarrhea, myelosuppression

Radiotherapy: anorexia, nausea, vomiting, weight loss, renal toxicity, diarrhea, myelosuppression

Dose modification

Cisplatin:

Patients developing significant nephrotoxicity, ototoxicity or sensory neurotoxicity should have the cisplatin discontinued.

Capecitabine

Anorexia In case of anorexia and weight loss > 10% since the start of the study nutritional support with a nasogastric or jejunal feeding tube is strongly recommended.

Hand-foot syndrome If painful swelling or erythema of hands occur, emollients are beneficial. Pyridoxin (vitamin B6) 50-150 mg/day has been reported to be of possible benefit to the patients. Pyridoxin is not licensed for this indication. In case of hand-foot syndrome grade ≥ 2, dosing should be interrupted until recovery ≤ grade 1. The omitted doses should not be

administered afterwards. When toxicity does not improve capecitabine will be discontinued for one week and restarted after a reduction of the dose with 25%.

Diarrhea Grade 1 diarrhea will be treated with loperamide or codeine phosphate. In case of diarrhea grade 2-4, capecitabine should be interrupted immediately and should only be restarted when diarrhea has resolved. If diarrhea persists for more than 48 hours despite recommended loperamide and codeine phosphate treatment, patients should be hospitalized for parenteral support and anti-diarrheal treatment (e.g. octreotide, tinctura opii).

Capecitabine dose modifications for non-haematological toxicity:

In case of a second episode of grade 2 or first episode of grade 3 toxicity, capecitabine should be restarted after a 25% dose reduction. In case of a second episode of grade 3 or first episode of 4 toxicity, capecitabine should be restarted after a 50% dose reduction. If toxicity recurs hereafter capecitabine should be discontinued.

Myelosuppression during chemoradiotherapy

Use worse CTC grade for either ANC or WBC

ANC	WBC	CTC grade	Dosing
≥ 2,0	≥ 4,0	0	Full dose
1,5 - 1,9	3,0 - 3,9	1	Full dose
1,0 - 1,4	2,0 - 2,9	2	Reduce cisplatin by 20% and continue capecitabine full dose.
0,5 - 0,9	1,0 - 1,9	3	Delay cisplatin and capecitabine until recovery. Then restart capecitabine after dose reduction of 25% and cisplatin after dose reduction of 20%
< 0,5	< 1,0	4	Delay cisplatin and capecitabine until recovery. Then restart and reduce capecitabine by 50% and cisplatin by 40%

In case of neutropenic fever delay cisplatin and capecitabine until recovery. Then restart and reduce capecitabine by 50% and cisplatin by 40%.

Platelets	CTC grade	Dosing
≥ 100	0	Full dose
75 - 99	1	Delay cisplatin until recovery and continue capecitabine full dose. Reduce cisplatin by 20% after recovery.
50 - 74	2	Delay cisplatin and capecitabine until recovery. Reduce cisplatin by 40% and continue capecitabine full dose.
25 - 49	3	Delay cisplatin and capecitabine until recovery. Then restart and reduce capecitabine by 25% and cisplatin by 60%
< 25	4	Delay capecitabine until recovery. Then restart capecitabine at 50%. Omit cisplatin from further treatment

B) Surgery

Preoperative assessment

Surgery will be planned 3-6 weeks after the last chemotherapy course. Assessment of ASA classification will be performed by an anaesthesiologist. The definitive decision to proceed to surgery will be taken based on the absence of signs of progressive disease and an ASA classification of 1 or 2.

Operation (38):

Operations will be under general anaesthesia supported by epidural anaesthesia. The standard approach will be a midline laparotomy, from xyphoid till below the umbilicus.

Intra-operative evaluation:

A complete exploration of the abdomen will take place, including observation and palpation of the stomach and surrounding structures, regional lymph nodes (N1, N2, N3), peritoneal surfaces, liver, and in women, ovaries. In case of doubt concerning tumor deposits outside the area to be resected, biopsies will be taken.

Any free abdominal fluid will be aspirated and stored in a heparin containing test tube for cytologic examination.

In case of absence of free fluid, peritoneal washings will be taken, rinsing the abdomen with 200 ml 0.9% saline and aspirating 10 cc in a test tube with heparin. Cytologic examination will be done immediately. In cases of doubt biopsy with frozen sections will be performed.

The following findings will be considered to make complete resection (R0) impossible:

- Tumor infiltration of the head of the pancreas needing a Whipple procedure for complete resection.
- N3 lymphnode metastases
- Tumor positive cytology of free peritoneal fluid or washings
- Peritoneal metastases if not directly adjacent to the primary, that cannot be included in the planned resection.

If curative resection (R0) is impossible, it will be up to the surgeon to decide on the best palliative surgical option.

Surgical technique

Principle of operation will be the wide resection of the tumor bearing part of the stomach en bloc with the N1 and N2 lymph nodes (D1+ resection). A luminal gastric margin of 5 cm will be the goal; for proximal lesions a 3 cm margin to the esophagus will be obtained and for lesions of the distal stomach a duodenal margin of 2 cm will be obtained. Adjacent organs will only be removed when there is suspicion on tumor involvement. Splenectomy and resection of pancreatic tail will not be done routinely.

Proximal 1/3 of the stomach

A total gastrectomy will be performed, from the distal esophagus till the proximal duodenum. The esophageal surgical margin will be examined by frozen section pathology.

Mid 1/3 of the stomach

A subtotal resection of the stomach will be performed, saving a small portion of stomach below the cardio-esophageal junction to facilitate reconstruction.

Distal 1/3 of the stomach

A distal 2/3 gastrectomy will be performed.

Diffuse tumors, Linitis plastica presentation

In principle a total gastrectomy with resection perigastric lymph nodes in clinical N0 cases will be done, with frozen sections of proximal and distal surgical margins. In clinical N1 cases additional resection of the nodes along the celiac axis, the common hepatic artery and the tail of pancreas will be performed.

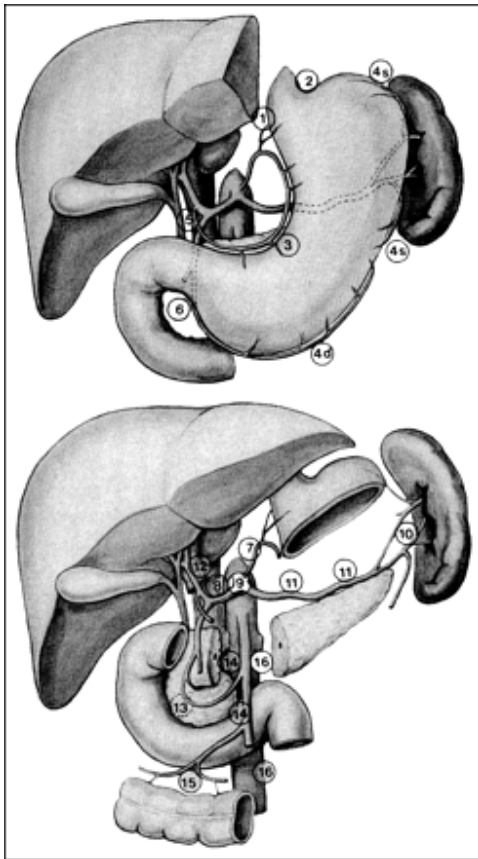
Lymphnode dissection (fig 1)

Lymph node stations surrounding the stomach.

- 1, right cardial nodes
- 2, left cardial nodes
- 3, nodes along the lesser curvature
- 4, nodes along the greater curvature
- 5, suprapyloric nodes
- 6, infrapyloric nodes
- 7, nodes along the left gastric artery
- 8, nodes along the common hepatic artery
- 9, nodes around the celiac axis
- 10, nodes at the splenic hilus
- 11, nodes along the splenic artery
- 12, nodes in the hepatoduodenale ligament
- 13, nodes at the posterior aspect of the pancreas head
- 14, nodes at the root of the mesentery
- 15, nodes in the mesocolon of the transverse colon
- 16, para-aortic nodes.

In order to perform extended surgery for gastric cancer a wide operative field should be achieved. Although several abdominal incision lines can be used, we prefer the vertical incision, after which the processus xiphoideus is removed. In order to obtain even a wider aperture strong retraction is needed pulling the left costal arch upwards. A lavage with saline is done to take samples for a cytology test. Although not yet commonly accepted, it is expected that in the future a positive cytology will be classified as P1 or P2. Routine and immunocytochemical staining will allow classification of cytological specimens as malignant or not.

At first the manoeuvre according to Kocher is performed in order to mobilize the duodenum and to evaluate the lymph node location 13 and 16 behind the pancreas and the aortic region. Subsequently omentectomy is performed. In general there is no vascular connection between the anterior and posterior layer of the mesocolon of the colon transversum. Therefore, these sheets can be divided relatively easily without any bleeding. The anterior sheet remains 'en bloc' with the greater omentum. Continuing one approaches the root of the mesentery making dissection of the locations 14 and 6 feasible including ligation of the right gastroepiploic vein and artery. After division of the minor omentum, along the liver and ligation of the right gastric artery, the duodenum can be divided. The stomach can now be pulled upwards, outside the abdomen onto the thorax.

The pancreas, the hepatoduodenal ligament and the celiac axis are now accessible. Subsequent dissection of lymph node location 12, 8, 9 and the first part of 11 can be done from right to left and from the pancreas towards the root of the left gastric artery. When the retroperitoneal tissue around the celiac axis is cleared and the left gastric artery is divided the dissection of this region is completed. If it is decided to perform a pancreaticosplenectomy, mobilization of the pancreas body and tail following the division of the mesocolon sheets will enhance the facility of splenectomy in a later stage. Complete mobilization of the spleen is done after the lymph node dissection of the celiac axis region is completed. The entire specimen of stomach, spleen and pancreas can be lifted from the retroperitoneum, leaving the left adrenal gland in situ. Division of the pancreas is done at the level of the inferior mesenteric vein or celiac axis. The pancreas is clamped, divided and the duct is ligated after which the stump is closed like a fish mouth. Optionally division of the pancreas is done by stapler. The strategy of lymph node dissection is based upon the anatomy of upper abdominal vessels, which are landmarks in the operating field.

Another aid is the injection of dye in a lymph node nearby the primary lesion. The lymph node pathways and connected nodes will colour quickly and point out the main locations to dissect.

Location number 1 (right cardiac nodes).

Borders: Perigastric nodes on the right sides of the cardia. Nodes along the cardio-esophageal branch of the left gastric artery, from its origin to the esophageal hiatus.

Dissection: The minor omentum is divided as cranial as possible along the inferior edge of the liver. Subsequently the peritoneal plica is incised over the abdominal esophagus. Proximally all the branches of the left gastric artery towards the stomach wall are ligated and divided as far as the resection line. If a node seems involved macroscopically, total gastrectomy should be performed.

Location number 3 and 5 (lesser curvature and suprapyloric nodes).

Location number 2 is combined with numbers 10 and 11.

Borders 3: nodes along the inferior branch of the left gastric artery and along the right gastric artery distal to the first gastric branch.

Borders 5: nodes at the origin of the right gastric artery including the first gastric branch.

Dissection: location number 3 is always removed when gastrectomy is performed, in distal, subtotal and total gastrectomy. Following the proper hepatic artery downwards the origin of the right gastric artery is looked for and subsequently divided.

Location number 4 (greater curvature nodes).

Borders: this location is divided into a left (s) and a right (d) part defined by the water shed. Subsequently the left part is divided into a proximal (sa) and a distal part (sb). 4sa is located around the short gastric arteries and 4sb are the nodes along the left gastroepiploic artery. 4d is located along the right gastroepiploic artery distal to the first gastric branch.

Dissection: In order to dissect 4sa a splenectomy is necessary. Location 4sb and 4d. the complete dissection of the anterior sheet of the mesocolon at the splenic flexure including the capsula of the pancreas tail, makes the access to the splenic hilus easy. The origin of the left epiploic artery can be found caudal to the tip of the pancreas tail. Dividing this artery will enable the 'en bloc' removal of 4sb and 4d with the stomach.

Location number 6 (infrapyloric nodes).

Borders: perigastric nodes on the greater curvature of the pylorus. Nodes along the gastroepiploic vessels from their origin to their first gastric branches. The origin of the vein is situated just after the gastrocolic trunk.

Dissection: By using the accessory right colic vein as a guide line, the gastrocolic trunk is found easily after which the right gastroepiploic vein can be divided. Sometimes the division of the pancreaticoduodenal vein is included as well. Dissection of the capsula is continued over the pancreas towards the common hepatic and gastroduodenal artery, which is followed caudally until the origin of the right gastroepiploic artery is reached and subsequently divided.

Location numbers 7, 8 and 9 (tripus Halleri nodes).

Borders 7: Nodes on the left gastric artery from its origin to the bifurcation into the cardioesophageal and lower branch.

Borders 8: Nodes around the common hepatic artery from the celiac trunk to the branching off of the gastroduodenal artery.

Borders 9: All nodes on the celiac axis including the origins of the common hepatic and splenic artery.

Dissection: Dissection is started from the left side of the hepatoduodenal ligament and the upper border of the pancreas towards the celiac axis until the origin of the left gastric artery is reached. All connective tissue including lymph nodes around the celiac axis and on the diaphragmatic crura is swept up towards the left gastric artery leaving the arteries completely naked. Subsequently the left gastric artery ligated and divided.

Location number 2 (left cardiac nodes).

Borders: Perigastric nodes on the left side of the cardia. Nodes along the cardio-esophageal branch of the left inferior phrenic artery.

Dissection: In case of distal gastrectomy dissection of number 2 is not indicated. With total gastrectomy the incision of the peritoneal plica over the esophagus is extended over the retroperitoneum. After division of the cardioesophageal branch at its origin of the left inferior phrenic artery, number 2 is included in the entire specimen.

Location numbers 10 and 11 (splenic hilus and artery).

Borders 10: All nodes at the splenic hilus, distal to the pancreas tip. At the lower pole, the first gastric branch of the left gastroepiploic artery defines the border between 10 and 4sb.

Borders 11: Nodes along the splenic vessels up to the distal end of the pancreas tail.

Dissection: Proper dissection is only achieved by distal pancreatectomy, because splenic artery twists behind the pancreas. Dissection might damage the pancreas. If the splenic artery is more or less located on top of the cranial margin of the pancreas, careful dissection might be possible starting from the celiac axis ending up with division of the artery at the tip of the pancreas tail. In order to perform a dissection of node group numbers 10 a splenectomy is essential.

Location number 12 (hepatoduodenal ligament nodes).

Borders: Group number 12 is divided up in three parts: 1. left side of the hepatic artery (12a), 2. right side of the ligament and posterior to the choledochal duct (12b) and 3. just posteriorly to the portal vein (12p).

Dissection: Dissection is started from the hilus after lengthening the existing incision of the plica of the minor omentum over the hepatoduodenal ligament. Then this incision is continued downwards on the right

side of the ligament. Subsequently the anterior is continued over the right side, dissecting 12b and 12p behind the portal vein and pushed through to the left side. Subsequently dissection is continued towards location 8 and 13, making an 'en bloc' removal possible.

Location number 13 (retropancreatic nodes).

Borders: Nodes along the superior and inferior posterior pancreaticoduodenal arteries on the posterior side of the pancreas. The portal vein marks the lateral left border of this location. The upper border of location 13 coincides with 12b and 12p.

Dissection: After Kochers' manoeuvre the descending duodenum can be turned over, visualizing the back of the pancreas head. The dissection layer of 12p is continued downwards to the pancreas head. Fibrous tissue with the lymphatic network and possible nodes is removed by careful preparation starting from the duodenum in the direction of the distal pancreas. The dissection must be performed with subtlety in order to avoid pancreatic damage with subsequent postoperative fistulization.

Location number 14 and 15 (root mesenterium and transverse mesocolon nodes).

Borders 14: Nodes along the superior mesenteric vessels. The lateral border is confined by the bifurcation of the gastrocolic trunk, the lower border by the branching off the jejunal veins and the upper border is typified by the origin of the superior mesenteric artery.

Borders 15: Nodes in the transverse mesocolon.

Dissection: The dissection is carried out starting on the middle colic vein towards the mesenteric vein. Dissection is continued around the mesenteric vein towards the gastrocolic vein. The origin of the three branches must be stripped: 1. gastroepiploic vein, 2. right accessory colic vein and 3. inferior pancreaticoduodenal vein. As for 15 a total resection of this group is only achieved when the transverse colon is removed as well, because of a T4 tumour.

Location number 16 (para-aortic nodes).

Borders: Nodes around the abdominal aorta and inferior caval vein. Right and left border are defined as the hili of the left and right kidney.

Dissection: The dissection of this region is generally limited to the region cranial to the inferior mesenteric artery up to the aortal hiatus, the left lateral border consists of the ovarian (spermatic) vein, the right border the caval vein. After ligating the left border, subsequent dissection is performed over the aorta, until the inferior mesenteric root is reached. The dissected tissue is now removed from this part towards the left renal vein and from the caval vein towards the left border. In this procedure from the right side of the aorta, dissection of the overlying tissue on the left adrenal vein should be continued until the origin of the left adrenal vein. Later from the left side, after complete mobilization of the spleen and pancreas tails, the

left superior layer of the membrane of Gelotta is dissected. The part of 16 located superior to the renal vein is dissected separately.

Postoperative procedures

During the operation several locations are landmarked with numbers. After the operation the specimen is looked after by one of the attending surgeons, who separates those lymph nodes not removed 'en bloc' and makes sure that the pathologist can easily reallocate the specific lymph node locations.

The stomach is primarily incised along the greater curvature (if the tumour is not located on the greater curvature). The position of the tumour and lengths of parameters, i.e. size of tumour and distances from the tumour borders to resection margins are measured with the specimen stretched gently. Then a simple drawing can be made.

Reconstruction

The Bilroth II reconstruction, with closure of the duodenal stump and the use of a Roux en Y loop of jejunum to make an anastomosis to the esophagus or proximal stomach will be the standard reconstruction technique. After distal gastrectomy a Bilroth I reconstruction can be considered. It will be up to the surgeon to choose his preferred reconstruction and the technique of closing it (hand sutured or stapled).

Miscellaneous

Routinely a jejunostomy will be inserted, either directly transabdominal or through the nasogastric pathway, with its tip 50 cm distal to the suture lines. A naso-gastric decompression tube is left at the level of the suture line. A drain is placed in the left sub-diafragmatic space.

IT IS STRONGLY ADVISED TO LEAVE A JEJUNOSTOMY IN UNTILL POSTOPERATIVE CHEMOTHERAPY OR CHEMORADIOTHERAPY HAS BEEN COMPLETED AND ORAL INTAKE IS ADEQUATE

Post-operative care

According to hospital protocols.

Pathology specimen

The specimen will be marked for proximal vs distal and for lesser curvature vs greater curvature. See paragraph on pathology for methods of tissue preserving for tissue banking purposes.

Quality Assurance of Surgery

A blinded, retrospective analysis of Dutch (D1 vs. D2) trial data suggests that low-MI surgery is associated with significantly increased survival. A dose-response effect with respect to the MI and survival is also apparent. We advocate using the Maruyama Program, a computerized tool based on patient experience, to identify nodal stations at risk, either preoperatively or intraoperatively, to customize surgical lymphadenectomy and routinely generate a low-MI operation. Our observations strongly suggest "dumping" D in favor of low-MI surgery. Level 1, prospective, randomized validation is the next step, and an international trial of this concept is currently being planned. At the very least, a compelling dose-response effect reveals MI to be a quantitative yardstick for assessing the adequacy of lymphadenectomy for gastric cancer. In the present time the Maruyama Index will be used postoperatively to assess the quality of surgery in relation to the randomisation: chemotherapy vs chemo/radiotherapy.

C) Radiotherapy

A separate CTV delineation manual with examples will be provided for radiation oncologists. These CTV guidelines are based on our own experience in gastric cancer radiotherapy, SWOG criteria and guidelines from the Trans-Tasman Radiation Oncology Group (TROG).

The goal of radiotherapy is to irradiate the tumor bed, anastomoses and regional lymph nodes with a margin to a dose of 45 Gy in 25 fractions of 1.8 Gy with a frequency of 5 fractions a week.

External beam (LINAC based) therapy will be used with minimum photon energies of 6 MV.

Simulation. All patients will have a CT-simulator and (if available) a conventional simulator session. Patients will be positioned supine with their arms above the head. At the CT-simulator an isocenter will be positioned a few centimeters left from the Th12 or L1 vertebra (depending on the position of the gastric tumor and the lymph node areas that are to be treated). A CT-scan with slice thickness of maximal 5 mm will be performed without contrast and will begin at the carina and end at the iliac crest. Complete volumes of the heart, liver and kidneys have to be encompassed. The isocenter and other localization marks for patient setup will be inked on the skin.

In proximal T3-4 tumors the upper border of the CTV has to encompass the most cranial position of the left hemidiaaphragm during breathing. This upper border can be visualized with conventional simulation or CT.

Target volume. The *Clinical Target Volume* (CTV) has to be delineated on CT-images based on all diagnostic information (gastroscopy, endoscopic ultrasound, clips, barium radiographs, preop CT, surgical notes). Also, on all CT slices heart, spinal cord, liver and kidneys have to be contoured. A postoperative diagnostic quality CT scan with iv contrast should be used to identify the gastric remnant, anastomoses, duodenal stump and regional lymph node stations (i.e. vascular structures). A digital CTV contouring atlas will be made available by the study coordinators and on the website of the DCCG (www.dccg.nl).

CTV. The target volume has to include the tumor bed, anastomoses and draining lymph node stations. Most practically, these three structures are identified in each CT slice and one CTV is contoured that encompasses all.

- **Anastomoses:** In patients that have had a partial distal gastrectomy, the gastrojejunal anastomosis and duodenal stump should be included in the CTV. After a total gastrectomy for proximal and GE-junction tumors the oesophagojejunal anastomosis has to be included. After an oesophagogastrectomy the anastomosis can be located high in the chest or neck, which makes it not suitable for irradiation.

Cave: for tumors of the GE-junction an extra margin of 4 cm of the oesophagus in the proximal direction is needed to encompass the para-oesophageal nodes

- **Tumor bed:** The gastric remnant should always be part of the CTV. Especially in T3-4 tumors it is obligatory to include the preoperative tumor extension in the CTV. The hepatogastric ligament (lesser omentum between lesser curvature and liver) needs to be included in all cases. The

anterior abdominal wall should **at least** be included in anteriorly located T3-4 tumors and in patients that had tumor extension to the abdominal wall. CTV will be extended to the lateral side as far as needed to include the preoperative tumor extension or to encompass lymph nodes that are to be treated.

- Regional Lymph Nodes: These consist of the N1 or perigastric nodes and the N2 or celiac, porta hepatis, gastroduodenal, splenic, suprapancreatic and retropancreatic nodes. In addition, for tumors of the proximal 1/3 of the stomach (cardia) **at least** lymphnode stations along the right and left side of the cardia, the lesser and greater curvature, infrapyloric, left gastric artery, common hepatic artery and celiac axis should be included in the CTV. For tumors of the middle 1/3 of the stomach (corpus) **at least** lymphnodes along the lesser and greater curvature, infrapyloric, left gastric artery and common hepatic artery should be included in the CTV. Finally, for tumors of the distal 1/3 of the stomach (antrum) **at least** lymphnodes along the right and left cardia, lesser and greater curvature, left gastric artery, celiac axis, splenic artery and hilum should be included in the CTV.

For tumors near (≤ 5 cm) the gastroduodenal junction a 5 cm extra distal margin to the duodenum has to be taken. For proximal gastric tumors with extension through the wall 2/3-3/4 of the left hemidiaphragm should be included in the CTV with a 1 cm margin.

PTV. In defining a *Planning target volume* (PTV) the CTV has to be expanded in all directions with a margin of 10 mm. An exception can be made on the dorsal side with respect to bony structures like vertebrae and both kidneys, where a margin of 5 mm will be sufficient.

Dose calculation, beam setup. All 3D conformal (or IMRT) techniques are allowed to get a homogeneous dose distribution in the PTV. AP-PA techniques are judged to be suboptimal and therefore not allowed. Radiation dose is specified at the intersection of the beams, i.e. the isocenter. According to the ICRU a minimum dose of -5% and maximum dose of +7% is allowed. All (multiple) beam setups are allowed. Shielding of critical structures is preferably done by MLC, but customized lead shielding is allowed. At least 2/3 of the volume of one (right) normally functioning kidney has to receive less than 40% of the prescribed dose. Furthermore, the mean liver dose may not exceed 30 Gy (physical dose).

The cardiac silhouette must not have greater than 30% of its area exposed to a total dose of 40 Gy

The spinal cord dose may not exceed 45 Gy.

To evaluate dose plans, DVH's have to be constructed of PTV, liver, left and right kidney and heart.

Treatment. Daily positioning on the linear accelerator has to be verified with epid (electronic portal imaging device) and/or conebeam CT techniques and, if necessary, corrected according to local institutional protocols. All fields have to be treated daily. If compensation due to holidays or other logistic reasons is needed, two fractions a day are not permitted. The overall treatment time should not exceed 38 days and daily fraction dose should remain unchanged.

Quality assurance of Radiotherapy.

Because most radiotherapy departments do not have a lot of experience with gastric cancer radiotherapy and to ensure uniformity of radiation treatment between all participating centers, target volume delineation manuals and workshops will be offered to all participating radiation oncologists. Furthermore, all centers will be asked to provide CTV contouring and treatment plans (with DVH's) to the study coordinators (EJ; MV) **before start of treatment** of the first 3 patients that are treated in that center. CTV and target coverage will be evaluated within 48 hours by the radiotherapy study coordinators and feedback will be given to the treating radiation oncologist.

Furthermore, treatment plans can be asked for **after treatment** at random by the study coordinators to secure uniformity in radiation treatment plans

D) Pathology

Processing and reporting of gastrectomy specimens is performed according to the Protocol of the Dutch Society for Pathology for gastrectomy specimens (see below). In all patients the extent of response will be specified (pCR or not).

Transport:

For biobanking purposes, delay between surgical resection and pathological processing should be as short as possible. Time of completing surgical resection and time of pathological processing and obtaining fresh samples should be registered.

Biobanking

In addition to tissue sampled for diagnostic purposes (and when tumor size allows), for the purpose of this study, the following samples are taken:

Fresh:

- 1 container with vital tumor tissue in liquid nitrogen or preservation fluid (will be provided)
- 1 container with normal mucosa (as far as possible from the tumor, no muscularis propria) in liquid nitrogen or preservation fluid (will be provided)

After overnight fixation in buffered 4% formaldehyde

- 1 paraffin block with vital tumor tissue
- 1 paraffin block with section through normal gastric wall, as far as possible from tumor (does include muscularis propria)
- duration of fixation should be registered

Pathology protocol:

MACROSCOPY:

- | | |
|-----------------------------|---|
| - Organ: | Total / partial stomach (with esophagus, duodenum, omentum (minor / major) or spleen) |
| - Length greater curvature: | in cm |
| - Length lesser curvature: | in cm |
| - Lesser omentum: | size in cm and if present relevant pathology |
| - Omentum: | size in cm and if present relevant pathology |
| - Others: | Perforation, etc. |

Tumor:

- Localisation: see remark 1.
- Aspect: Flat, ulcerative, polyp
- Size: 2 largest dimensions.
- Surgical margins: Free? Yes/No; distance proximal and distal in cm.
- Depth of invasion: Submucosa, muscularis propria, subserosa.
- Serosa at site of tumour: Intact, normal, white, perforation, inflammation, relation to tumour.
- Mucosa: Polyp, ulcer, inflammation.
- Others: Status other organs and relevant pathology.

Lymph nodes:

- Marked lymph nodes (as marked by the surgeon, see surgical procedure):
- Number of lymph nodes (lesser curvature):
- Number of lymph nodes (greater curvature):

Blocks:

- At least 2x tumor: deepest invasion, threatened serosal surface, junction tumour-normal mucosa.
- Both gastric surgical mucosal margins.
- In case of a proximal tumour: junction esophagus/stomach for diagnosis of Barrett carcinoma.
- 1x representative omentum or more in case of diffuse carcinoma.
- All lymph nodes.
- Frozen tissue: tumour and normal gastric mucosa
- Additional tumour and normal gastric mucosa for research purposes.

MICROSCOPY:

- Tumour type: According to WHO (see remark 2).
- Depth of invasion: Mucosa, submucosa, muscularis propria, subserosa, adjacent structures.
- Angioinvasion: Yes / No.
- Surgical margins: Free of tumour? Yes / No; if close (< 1cm) distance in mm.
- Serosal surface: Free of tumour? Yes / No; if close (< 1cm) distance in mm.
- Other mucosal pathology: Polyps, dysplasia, inflammation, etc.
- Regional lymph nodes: Number positive / negative.
- Marked lymph nodes: Number positive / negative.

CONCLUSION:

Tumour type, grade of differentiation, localisation in the stomach, size, depth of invasion, surgical mucosal margins. Partial or complete response (path PR orCR).

Number of lymph nodes and number of positive lymph nodes.

Other relevant pathology.

Remark 1.

If more than 50% of the tumour is localised in the esophagus, it is classified as a esophageal carcinoma. If less than 50% of the tumour is localised in the esophagus, it is classified as gastric carcinoma. If this is macroscopically uncertain, a planocellular and small cell carcinoma are classified as esophageal carcinoma. A adenocarcinoma is classified as gastric carcinoma.

Localisation of an adenocarcinoma in the esophagus in absence of a Barrett esophagus is classified as extension of a carcinoma of the cardia.

Remark 2: WHO classification 2000

Benign: - Adenoma

Malignant:

- Adenocarcinoma
 - Intestinal type
 - Diffuse type
- Papillary adenocarcinoma
- Tubular adenocarcinoma
- Mucinous adenocarcinoma
- Signet cell carcinoma
- Adenosquamous carcinoma
- Squamous cell carcinoma
- Small cell carcinoma
- Undifferentiated carcinoma
- Carcinoid (low grade neuroendocrine carcinoma)

9. ADVERSE EVENTS AND SCORING OF TOXICITY

The NCI Common Toxicity Criteria (CTC version 3.0) will be used to score acute (<90 days) radiation and chemotherapy toxicity. Adverse event (AE) – definition: Any untoward medical occurrence in a subject participating in this study. An AE does not necessarily have causal relationship with the study drug or radiotherapy. For this study all AEs will be reported on the CRF. AEs will be collected from the time the subject signs the informed consent. They include any change from the subject's pretreatment (screening) condition as symptoms or physical findings. An abnormal laboratory value may be considered an AE if the identified abnormality leads to any type of intervention, e.g. withdrawal of the study treatment, withholding treatment pending additional investigations.

AEs will be graded according CTC criteria (see appendix 2). Those not covered by these criteria will be graded on a 3-point scale (mild – moderate – severe).

Mild	- discomfort noticed, no disruption normal daily activity
Moderate	- discomfort sufficient to reduce or affect daily activity
Severe	- incapacitating, with inability to work or perform daily activity

Serious Adverse Events (SAE) are defined as follows according GCP-rules:

- results in death
- life threatening
- requires inpatient hospitalization or prolongation of existing hospitalization
- results in persistent or significant disability/incapacity, or
- is a congenital anomaly/birth defect

All SAEs, irrespective of relationship to the study treatment must be reported to the **Trial Office at the Netherlands Cancer Institute – Antoni van Leeuwenhoek Hospital by telephone (+31 20 512 2668; Monday – Friday 8.30 – 17.00 hr) or by fax (+31 20 512 2679) or by e-mail (trialbureau@nki.nl)** as soon as possible, but no later than one working day. The SAE report should include the investigator's assessment of causality. If follow-up information changes the investigator's assessment of causality, this should be noted on the follow-up SAE form. SAEs occurring within 30 days after discontinuation of the study treatment should be reported.

10. SIDE STUDIES:

1. After finishing patients accrual and analysis of survival, the value of the Maruyama index (35) and of the Memorial Sloan-Kettering Cancer Center predictive nomograms for gastric cancer (34) survival will be investigated. The Maruyama index reflects the extent of non-resected pathological lymph nodes in gastric cancer, based on preoperative assessment of prognostic factors age, sex, Borrmann classification, histology, depth of wall penetration and diameter of the tumor. Because patients in this study will have identical surgery in both arms, it will be investigated whether this index can predict which patients benefit the most from either postoperative treatment. The MSKCC nomogram uses patient characteristics and surgicopathological findings to predict survival. In this study it will be investigated if this is also applicable to patients that have neoadjuvant chemotherapy and postoperative chemotherapy or chemoradiotherapy.

2. TRANSLATIONAL RESEARCH:

Gastric cancer develops by accumulation of chromosomal and/or (epi)genetic changes. Different clinical and phenotypical characteristics of gastric cancer, like invasive potential and drug responsiveness, are believed to be associated with different patterns of (epi)genetic alterations. However, the exact genomic abnormalities involved are largely unknown. Tumor tissue and serum collected from patients included in the CRITICS trial will be used to elucidate the patterns of biological alterations present in gastric cancer, and to find specific biomarkers that may predict clinical outcome.

a. Correlation of histopathological parameters with clinical outcome:

Review of pathology of resected gastric cancer specimens will be performed (prof.dr. G.A. Meijer and dr. N.C.T. van Grieken, dept. of pathology, VU Medical Center, Amsterdam). Histopathological parameters (including type of tumour, depth of invasion, presence of lymph node metastases (TNM stage), EBV-status and tumour regression) will be correlated to overall survival and response to therapy.

b. Tissue collection for translational research:

After informed consent, patients will be asked to undergo an additional optional gastroscopy before start of treatment in order to collect additional biopsy specimens (in formalin and RNA later) from the tumour. In this way, tumour tissue that is unaffected by chemotherapeutic agents is obtained and can be used for translational studies. It is emphasized that this gastroscopy is optional and if patients refuse, this does not affect their treatment.

Three (heparinized) tubes of blood (7-10 ml) will be collected at different time points: before start of the chemotherapy, before and after surgery, after completion of adjuvant chemo(radio)therapy, and yearly during follow up, mainly for EBV-related studies and proteomics (see 10.2.d and 10.2.e).

In addition, tissue will be collected from gastrectomy specimens. After all material needed for an optimal histopathological diagnosis and complete pathology report is collected, tissue will be collected for translational research. This will never interfere with good histopathological practice. Both normal mucosa and tumour tissue will be fixed in formaldehyde and embedded in paraffin. This material will be used for

tissue micro-arrays, morphological and immunohistochemical studies. Also, both normal mucosa and tumour tissue will be frozen and stored in liquid nitrogen. DNA and / or RNA will be isolated from this material in order to perform microarrays, Multiplex Ligation-dependent Probe Amplification (MLPA) and other (epi)genetic essays.

c. Correlation of genomic changes in the tumour with clinical outcome:

The main purpose of translational research in the CRITICS study is to find biomarkers that may predict clinical outcome. Several laboratory essays will be used to detect genomic changes. These tests include tissue microarray (TMA), immunohistochemistry (IHC), microarray CGH, Multiplex Ligation-dependent Probe Amplification (MLPA), methylation studies and possibly other (epi)genetic assays. Previously, CGH has shown that chromosomal changes frequently occur in gastric cancer.¹ In addition, array-CGH has proven its clinical relevance by predicting presence of lymph node metastases and prognosis in gastric cancer patients.² Chemotherapeutic agents are known to induce (epi)genetic changes, like for instance hypermethylation. By correlating the results from different essays to response to different therapies, overall survival and disease free survival, the present study may provide us biomarkers that can predict which patients may benefit from specific treatment strategies. In the future, this may protect patients from severe treatment complications if it will become clear that they would not have responded to the treatment anyway. Furthermore, patients who will respond may be offered the optimal treatment strategy. Also, based on these studies new targets for chemotherapeutic agents may be identified.(39;40)

d. EBV-associated gastric cancer:

Worldwide approx. 10% (range 6-16%) of gastric adenocarcinoma are associated with Epstein-Barr virus (EBV) infection, showing distinct viral gene expression in the tumour cells. Both tumour tissue and blood will be used for EBV-related side studies that focus on EBV involvement, EBV dynamics and anti-EBV immune reactivity in gastric cancer patients as well as the relationship between EBV-parameters and clinical response to therapy.

e. Proteomics:

Genomic alterations may lead to changes in protein expression in the tumour as well as in blood. Proteomics studies using mass spectrometry will be performed providing serological protein profiles. These profiles will be correlated to response to different therapies, overall survival and disease free survival. Specific serological protein profiles may provide biomarkers for the early detection and/or the monitoring of gastric cancer.

11. QUALITY OF LIFE STUDIES:

Quality of life studies will also be performed before start treatment (baseline); after neoadjuvant chemotherapy; after surgery and after one of both adjuvant strategies.

Study instruments:

EORTC QLQ-C30 (Version 3.0)

The EORTC QLQ-C30 is a multidimensional, cancer-specific quality-of-life questionnaire developed by the European Organization for Research and Treatment of Cancer (EORTC) Study Group on Quality of Life for use in international clinical trial settings. The questionnaire is designed for use with a wide range of cancer patient populations, irrespective of specific diagnosis. It can be supplemented by optional questionnaire modules developed for specific diagnostic groups or for specific treatment modalities.

The EORTC QLQ-C30 includes 5 functional scales (physical, role, emotional, social and cognitive functioning), 3 symptom scales (fatigue, pain, and nausea and vomiting), a global health status/quality of life scale, and a number of single items assessing additional symptoms (dyspnea, sleep disturbance, constipation and diarrhea) and perceived financial impact.

For the majority of the EORTC QLQ-C30 items a 4-point Likert-type response scale is used. The only exception is the global health status/quality of life scale (where a 7 point scale is used). For ease of presentation and interpretation, all subscale and individual item responses are linearly converted to a 0 to 100 scale. For the functional and global quality of life scales, a higher score represents a better level of functioning. For the symptom scales and items, a higher score reflects a greater degree of symptomatology.

EORTC QLQ-STO22

The gastric cancer module is meant for use among a wide range of patients with adenocarcinoma of the stomach. The module includes 22 items concerning disease- and treatment-related symptoms and side-effects, dysphagia, nutritional aspects and items about the emotional problems of gastric cancer.

12. STATISTICS

The study endpoint will be overall survival (OS). For sample size calculations the 5 year OS figures from 3 large gastric cancer randomized studies are used. The SWOG and MAGIC study report 5 yr OS of 22 and 23% in their surgery only arms respectively. On the contrary the Dutch Gastric Cancer study reported 5 yr OS of 45 and 47% with D1 and D2 surgery respectively. The MAGIC study showed an absolute increase of OS at 5 yrs of 13%.

It is therefore hypothesized that in this study 5 yr OS after neoadjuvant chemotherapy followed by D1+ surgery will be about 40%. In the experimental arm (with chemoradiation) the projected 5 yr OS will be 50%. Furthermore, it is expected that 10% of patients will drop out of the study due to progressive disease.

In order to achieve 80% power to detect a difference between 40% and 50% in 5 yrs OS, at a significance level of 0.05, allowing for 10% loss to follow-up, 430 events are required. The hazard ratio of the experimental arm with respect to the control arm equals 0.76.

Based on 4 years of accrual, and three additional years of follow-up after the last patient has been included, according to a two-tailed analysis **788** patients would be required to reach these 430 events. This is feasible with a yearly accrual of 197 patients per year. After an accrual time of 4 years and 3 years of follow up the median follow up time will be 5 years.

INTERIM ANALYSIS

An interim analysis will be performed when half of the required number of events have been observed. Based on the O'Brien-Fleming alpha-spending function, the first analysis will be performed at nominal alpha level 0.003, the second at nominal alpha level 0.047, to ensure an overall alpha of 0.05.

Formal interim analyses of the accumulating data will be performed for review by an Independent Data Monitoring Committee (IDMC). The IDMC will be asked to give advice on whether the accumulating data from the trial with the guidelines for discontinuation of accrual, together with results from any other relevant trials, justifies continuing recruitment of further patients or further follow-up. A decision to discontinue recruitment, in all patients or in selected subgroups will be made only if the result is likely to convince a broad range of clinicians including those entering patients into the trial and the general clinical community. If a decision is made to continue, the IDMC will advise on the frequency of future reviews of the data on the basis of accrual and event rates. The IDMC will make recommendations to the principal investigators as to whether the trial should continue in its present form. While the trial is ongoing the accumulating data will remain confidential.

Statistical paragraph for Quality of Life data analysis**1. Basic scoring of the EORTC QLQ-C30 and the STO22**

The EORTC QLQ-C30 and the STO22 will be scored according to the standard procedures recommended by the EORTC, with multi-item scales and single item measures being linearly transformed to a 0 to 100 scale.

2. Handling of missing item responses

It is not uncommon that, for any given patient, responses to one or more questions will be missing. Based on previous experience with the EORTC QLQ-C30, it is expected that the missing item value rate will be less than 5%.

In the case of missing responses for one or more items of the multi-item scales, a "half-scale" option will be followed. This procedure requires that at least one half of the responses to the items of a given scale are available. The missing item responses are then replaced with the mean score for the remaining items of the scale for that patient. If more than half of the item responses for a given multi-item scale are missing, then the scale score for that patient will be treated as missing. Missing values for single item measures will be treated as missing in the analysis.

Statistical testing of change in EORTC QLQ-C30 and the QLQ-STO22 scores over time.

The statistical significance of the difference of observed mean changes between treatment arms in QLQ-C30 and QLQ-STO22 scores over time will be tested by means of the mixed effect modeling procedure (SAS proc mixed). All patients with at least one follow up will be included in the estimated model of change over time.

13. ETHICS

The study protocol has been reviewed and approved by the Protocol Toetsings Commissie / Medical Ethical Committee of the Netherlands Cancer Institute / Antoni van Leeuwenhoek Hospital. Patients will receive information (orally and written) about the study. Registration at the data center and treatment can only start when patients have signed a written informed consent

14. RANDOMISATION, DATA MANAGEMENT AND ANALYSIS

Patient randomisation will only be accepted from authorised investigators or through their authorised datamanager or authorised staff member. A patient can be randomised only after verification of eligibility. This must be done **before the start of the protocol treatment**. Randomisation will be performed centrally by the Central Data Center: The LUMC Datacenter Surgery. Randomisation can be done by telephone (**+31 71 526 3500; Monday-Friday; 8.30-17:00**) or by fax (+31 71 526 6744). During randomisation procedure eligibility criteria will be checked.

Randomisation must take place within 2 weeks of histological diagnosis of primary gastric cancer.

Standard questions

- ◆ Institute (number)
- ◆ Name of the investigator
- ◆ Profession of the investigator
- ◆ Patient's birth date (day/month/year)
- ◆ Patient's chart number or initials

Protocol specific questions

- ◆ Eligibility criteria
- ◆ Date of written consent
- ◆ Quality of Life participation
- ◆ Lauren classification
- ◆ Tumour localisation
- ◆ Clinical T stage
- ◆ Sex

After the randomisation, a sequential identification number will be given. This number has to be recorded on the randomisation form, along with the randomisation date. The randomisation form must be signed by the investigator (in case of faxed randomisation, the confirmation of the data manager will also have to be signed by the investigator) and be filed with the Case Report Forms.

FORMS AND PROCEDURES FOR COLLECTING DATA

Data will be reported on the CRITICS forms. The investigator/datamanager should send completed forms to:

Leids Universitair Medisch Centrum (LUMC)

Datacenter Heelkunde, K6-R

Postbus 9600

2300 RC LEIDEN

Nederland

The list of forms to be completed for this study and their submission schedule is appended to the set of case report forms

Data flow

The case report form must be completed, dated and signed by the investigator or one of his/her authorised staff members as soon as the requested information is available. The list of staff members authorised to sign case report forms (with a sample of their signature) must be sent to the Central Data Center by the responsible investigator before the start of the study. In all cases, it remains the responsibility of the investigator to check that original case report forms are sent to the Central Data Center and that they are completely and correctly filled out.

The original copy must be returned to the Central Data Center and the investigator must keep a copy.

The Central Data Center will perform extensive consistency checks on the CRFs and issue Query Forms in case of inconsistent data that will be sent to the investigator. Those Query Forms must be answered and signed by the investigator (or an authorised staff member). The original must be returned to the Central Data Center and a copy must be appended to the investigator's copy of the CRFs.

If an investigator (or an authorised staff member) needs to modify a CRF after the original copy has been returned to the Central data Centre, he / she should notify the Central Data Centre in writing (and sign the notification) and append a copy of the notification to his own copy of the CRFs.

The investigator's copy of the CRFs may not be modified unless modifications are reported on a Query Form (or a written and signed notification) and the Query Form (or notification) reference is indicated on the CRF.

- ◆ Upon occurrence of a Serious Adverse Event
- ◆ All Serious Adverse Events (SAE) occurring **during the treatment period and within 30 days after the end of the last protocol treatment** must be faxed to the Central Data Centre.
- ◆ All SAEs related to the protocol treatment, and occurring after this 30-day period must also be reported to the Central Data Centre
- ◆ All SAEs related to the protocol treatment must be reported by fax **within 24 hours** of the initial observation
- ◆ A completed SAE-form must be returned to the Central Data Centre within 10 calendar days of the initial observation of the SAE
- ◆ **All forms must be dated and signed by the responsible investigator or one of his/her authorised staff members.**

15. PUBLICATION

The final publication of the trial results will be written by one of the principal investigators on the basis of the final analysis performed at the LUMC Data Center. After revision by the Data Center and other co-authors the manuscript will be sent to a major scientific journal. Authors of the manuscript will include at least the Study Coordinators, the investigators who have included more than 5% of the eligible patients in the trial (by order of inclusion), and members of the Data Center team who have contributed to the trial.

If the group wishes to publish or present study data before this final publication, those will never include comparisons between randomized treatment arms before the number of events required by the protocol for the primary end-point of interest have been observed.

All manuscripts will include an appropriate acknowledgment section, mentioning all investigators who have contributed to the trial, as well as supporting bodies.

The principal investigators and the Data Center must approve all publications, abstracts and presentations based on patients included in this study. This is applicable to any individual patient registered/randomized in the trial, or any subgroup of the trial patients. Such a publication cannot include any comparisons between randomized treatment arms nor an analysis of any of the study end-points unless the final results of the trial have already been published by the principal investigators.

16. REFERENCES

1. Gunderson LL, Sosin H: Adenocarcinoma of the stomach: areas of failure in a re-operation series (second or symptomatic look) clinicopathologic correlation and implications for adjuvant therapy. *Int J Radiat Oncol Biol Phys* 8:1-11, 1982
2. Landry J, Tepper JE, Wood WC, et al: Patterns of failure following curative resection of gastric carcinoma. *Int J Radiat Oncol Biol Phys* 19:1357-1362, 1990
3. Jansen E, Boot H, Verheij M, et al: Optimal Locoregional Treatment in Gastric Cancer. *J Clin Oncol* 23:4509-4517, 2005
4. Hartgrink HH, van de Velde CJ, Putter H, et al: Extended lymph node dissection for gastric cancer: who may benefit? Final results of the randomized Dutch gastric cancer group trial. *J Clin Oncol* 22:2069-2077, 2004
5. Cuschieri A, Weeden S, Fielding J, et al: Patient survival after D1 and D2 resections for gastric cancer: long-term results of the MRC randomized surgical trial. Surgical Co-operative Group. *Br J Cancer* 79:1522-1530, 1999
6. van de Velde CJ, Peeters KC: The gastric cancer treatment controversy. *J Clin Oncol* 21:2234-2236, 2003
7. Petrelli NJ: The debate is over; it's time to move on. *J Clin Oncol* 22:2041-2042, 2004
8. Hallissey MT, Dunn JA, Ward LC, et al: The second British Stomach Cancer Group trial of adjuvant radiotherapy or chemotherapy in resectable gastric cancer: five-year follow-up. *Lancet* 343:1309-1312, 1994
9. Earle CC, Maroun JA: Adjuvant chemotherapy after curative resection for gastric cancer in non-Asian patients: revisiting a meta-analysis of randomised trials. *Eur J Cancer* 35:1059-1064, 1999
10. Gianni L, Panzini I, Tassinari D, et al: Meta-analyses of randomized trials of adjuvant chemotherapy in gastric cancer. *Ann Oncol* 12:1178-1180, 2001
11. Hermans J, Bonenkamp JJ, Boon MC, et al: Adjuvant therapy after curative resection for gastric cancer: meta-analysis of randomized trials. *J Clin Oncol* 11:1441-1447, 1993
12. Janunger KG, Hafstrom L, Glimelius B: Chemotherapy in gastric cancer: a review and updated meta-analysis. *Eur J Surg* 168:597-608, 2002
13. Mari E, Floriani I, Tinazzi A, et al: Efficacy of adjuvant chemotherapy after curative resection for gastric cancer: a meta-analysis of published randomised trials. A study of the GISCAD (Gruppo Italiano per lo Studio dei Carcinomi dell'Apparato Digerente). *Ann Oncol* 11:837-843, 2000
14. Cunningham D, Allum WH, Stenning SP et al: Perioperative chemotherapy in operable gastric cancer and lower oesophageal cancer: final results of a randomised, controlled trial (the MAGIC trial, ISRCTN 93793971). *Proc Am Soc Clin Oncol* 2005
15. Hoff PM, Ansari R, Batist G, et al: Comparison of oral capecitabine versus intravenous fluorouracil plus leucovorin as first-line treatment in 605 patients with metastatic colorectal cancer: results of a randomized phase III study. *J Clin Oncol* 19:2282-2292, 2001
16. Scheithauer W, McKendrick J, Begbie S, et al: Oral capecitabine as an alternative to i.v. 5-fluorouracil-based adjuvant therapy for colon cancer: safety results of a randomized, phase III trial. *Ann Oncol* 14:1735-1743, 2003

17. Van Cutsem E, Twelves C, Cassidy J, et al: Oral capecitabine compared with intravenous fluorouracil plus leucovorin in patients with metastatic colorectal cancer: results of a large phase III study. *J Clin Oncol* 19:4097-4106, 2001
18. Evans TR, Pentheroudakis G, Paul J, et al: A phase I and pharmacokinetic study of capecitabine in combination with epirubicin and cisplatin in patients with inoperable oesophago-gastric adenocarcinoma. *Ann Oncol* 13:1469-1478, 2002
19. Cho EK, Lee WK, Im SA, et al: A phase II study of epirubicin, cisplatin and capecitabine combination chemotherapy in patients with metastatic or advanced gastric cancer. *Oncology* 68:333-340, 2005
20. Sumpter K, Harper-Wynne C, Cunningham D, et al: Report of two protocol planned interim analyses in a randomised multicentre phase III study comparing capecitabine with fluorouracil and oxaliplatin with cisplatin in patients with advanced oesophagogastric cancer receiving ECF. *Br J Cancer* 92:1976-1983, 2005
21. Macdonald JS, Smalley SR, Benedetti J, et al: Chemoradiotherapy after surgery compared with surgery alone for adenocarcinoma of the stomach or gastroesophageal junction. *N Engl J Med* 345:725-730, 2001
22. Hundahl SA, Macdonald JS, Benedetti J, et al: Surgical treatment variation in a prospective, randomized trial of chemoradiotherapy in gastric cancer: the effect of undertreatment. *Ann Surg Oncol* 9:278-286, 2002
23. al Sarraf M, Martz K, Herskovic A, et al: Progress report of combined chemoradiotherapy versus radiotherapy alone in patients with esophageal cancer: an intergroup study. *J Clin Oncol* 15:277-284, 1997
24. Bartelink H, Roelofsen F, Eschwege F, et al: Concomitant radiotherapy and chemotherapy is superior to radiotherapy alone in the treatment of locally advanced anal cancer: results of a phase III randomized trial of the European Organization for Research and Treatment of Cancer Radiotherapy and Gastrointestinal Cooperative Groups. *J Clin Oncol* 15:2040-2049, 1997
25. Bernier J, Dommenege C, Ozsahin M, et al: Postoperative irradiation with or without concomitant chemotherapy for locally advanced head and neck cancer. *N Engl J Med* 350:1945-1952, 2004
26. Rose PG, Bundy BN, Watkins EB, et al: Concurrent cisplatin-based radiotherapy and chemotherapy for locally advanced cervical cancer. *N Engl J Med* 340:1144-1153, 1999
27. Schaake-Koning C, van den Bogaert W, Dalesio O, et al: Effects of concomitant cisplatin and radiotherapy on inoperable non-small-cell lung cancer. *N Engl J Med* 326:524-530, 1992
28. Byfield JE, Calabro-Jones P, Klisak I, et al: Pharmacologic requirements for obtaining sensitization of human tumor cells in vitro to combined 5-Fluorouracil or fluorouracil and X rays. *Int J Radiat Oncol Biol Phys* 8:1923-1933, 1982
29. Kjellstrom J, Kjellen E, Johnsson A: In vitro radiosensitization by oxaliplatin and 5-fluorouracil in a human colon cancer cell line. *Acta Oncol* 44:687-693, 2005
30. Rodel C, Grabenbauer GG, Papadopoulos T, et al: Phase I/II trial of capecitabine, oxaliplatin, and radiation for rectal cancer. *J Clin Oncol* 21:3098-3104, 2003
31. Vaishampayan UN, Ben Josef E, Philip PA, et al: A single-institution experience with concurrent capecitabine and radiation therapy in gastrointestinal malignancies. *Int J Radiat Oncol Biol Phys* 53:675-679, 2002
32. Kollmannsberger C, Budach W, Stahl M, et al: Adjuvant chemoradiation using 5-fluorouracil/folinic acid/cisplatin with or without paclitaxel and radiation in patients with completely resected high-risk gastric cancer: two cooperative phase II studies of the AIO/ARO/ACO. *Ann Oncol* 16:1326-1333, 2005

33. Dewit L, Anninga JK, Hoefnagel CA, et al: Radiation injury in the human kidney: a prospective analysis using specific scintigraphic and biochemical endpoints. *Int J Radiat Oncol Biol Phys* 19:977-983, 1990
34. Kattan MW, Karpeh MS, Mazumdar M, et al: Postoperative nomogram for disease-specific survival after an R0 resection for gastric carcinoma. *J Clin Oncol* 21:3647-3650, 2003
35. Maruyama K, Gunven P, Okabayashi K, et al: Lymph node metastases of gastric cancer. General pattern in 1931 patients. *Ann Surg* 210:596-602, 1989
36. Peeters KC, Kattan MW, Hartgrink HH, et al: Validation of a nomogram for predicting disease-specific survival after an R0 resection for gastric carcinoma. *Cancer* 103:702-707, 2005
37. Peeters KC, Hundahl SA, Kranenbarg EK, et al: Low maruyama index surgery for gastric cancer: blinded reanalysis of the Dutch d1-d2 trial. *World J Surg* 29:1576-1584, 2005
38. van de Velde CJ, Sasako M: Surgical treatment of gastric cancer: anatomical borders and dissection of lymph nodes. *Ann Chir Gynaecol* 87:89-98, 1998
39. van Grieken NC, Weiss MM, Meijer GA, et al: Helicobacter pylori-related and -non-related gastric cancers do not differ with respect to chromosomal aberrations. *J Pathol* 192:301-306, 2000
40. Weiss MM, Kuipers EJ, Postma C, et al: Genomic profiling of gastric cancer predicts lymph node status and survival. *Oncogene* 22:1872-1879, 2003

APPENDIX A) Patient information and informed consent form (Dutch)



Patiënteninformatie en toestemmingsformulier **CRITICS-studie** (deel 1)

Onderzoek naar het verschil in effect tussen gecombineerde chemotherapie en bestraling vergeleken met chemotherapie alleen, na chemotherapie en operatieve behandeling van maagkanker.

Een fase III studie waarin het effect van bestraling met gelijktijdige chemotherapie na operatie wordt vergeleken met chemotherapie alleen.

Oorspronkelijke Engelse titel: A multicenter randomized phase III trial of neo-adjuvant chemotherapy followed by surgery and chemotherapy or by surgery and chemoradiotherapy in resectable gastric cancer (CRITICS-study: ChemoRadiotherapy after Induction chemoTherapy In Cancer of the Stomach)

Zeer geachte meneer/mevrouw,

Door uw behandelend arts is met u gesproken over deelname aan een onderzoek, waarin bij patiënten met maagkanker na de operatieve behandeling (en daaraan voorafgaande chemotherapie), de waarde van radiotherapie (bestraling) gecombineerd met chemotherapie wordt vergeleken met die van alleen chemotherapie. De hieronder volgende schriftelijke informatie is bedoeld als aanvulling op de informatie die u reeds door uw behandelend arts is meegedeeld.

Achtergrond van het onderzoek

Operatie is de belangrijkste vorm van behandeling van maagkanker. Volgens de huidige inzichten lijkt het vooral van belang te zijn dat hierbij de maagtumor in zijn geheel verwijderd wordt en dat tegelijkertijd zoveel mogelijk lymfeklieren rondom het maaggebied verwijderd worden. Helaas komt de ziekte na operatie bij meer dan de helft van de patiënten terug. Vaak is dit op de plek waar het oorspronkelijke kankerproces heeft gezeten, soms treden uitzaaiingen op in andere delen in het lichaam.

Met aanvullende behandelingen zowel *voor* als *na* de operatie wordt geprobeerd de kans dat de ziekte terugkomt te verkleinen en op die manier de kans op genezing te vergroten.

In het verleden zijn hiervoor verschillende soorten chemotherapie (celdodende medicijnen) en radiotherapie (bestraling) afzonderlijk gebruikt.

De resultaten van deze onderzoeken waren veelal teleurstellend.

Recent zijn bij verschillende andere vormen van kanker onderzoeken verricht, waarbij de gelijktijdige combinatie van chemotherapie en radiotherapie leidde tot betere resultaten dan behandeling met één van beide afzonderlijk. Uit onderzoeken is bekend dat vooral het gelijktijdig geven van radiotherapie en chemotherapie het meest werkzaam is. Er is bij allerlei vormen van kanker (hoofd-hals, slokdarm, long en

baarmoederhals) veel ervaring opgedaan met het combineren van radiotherapie met chemotherapie. Hierbij is gebleken dat het middel cisplatin in lage doseringen de werking van bestraling kan versterken.

In een recent groot Amerikaans onderzoek met 556 patiënten is gebleken dat een gecombineerde aanvullende behandeling met radiotherapie en chemotherapie met het middel 5FU (5-fluorouracil) na de operatie leidde tot het minder vaak terugkomen van de ziekte in vergelijking met de groep patiënten die alleen werd geopereerd.

Een paar jaar geleden is het middel capecitabine (Xeloda[®]) beschikbaar gekomen dat als tablet kan worden ingenomen en dat goed via de darmen opgenomen wordt in het lichaam. Capecitabine heeft dezelfde werking als 5FU. Deze gegevens vormden voor ons de aanleiding om de werking te bestuderen van de combinatie van bestraling en chemotherapie met capecitabine en cisplatin na een operatie voor maagkanker. Dit onderzoek heeft inmiddels geleid tot een optimaal doseringsschema van deze middelen in combinatie met bestraling na een operatie.

Zeer recent Brits onderzoek heeft aangetoond dat, indien patiënten zowel vóór als na de maagoperatie 3 kuren chemotherapie ontvingen, het aantal geslaagde operaties en de overleving toenam. Dit lijkt vooral te worden verklaard door de kuren die vóór de operatie werden gegeven.

In de internationale medische gemeenschap is het op dit moment onduidelijk wat nu de optimale behandeling voor maagkanker is. Wij willen in dit aan u voorgestelde onderzoek nagaan of de combinatie van chemo- en radiotherapie, na een adequate maagoperatie en daaraan voorafgaande chemotherapie, leidt tot een gunstigere overleving van maagkankerpatiënten. Voor dit onderzoek vragen wij u om medewerking.

Wat is het doel van het onderzoek

Het betreft een fase III onderzoek. Dit betekent het volgende. Voor u bestaat in Nederland een standaardbehandeling voor maagkanker, namelijk een maagoperatie. Bij grotere tumoren wordt steeds vaker voor de operatie chemotherapie gegeven. En daarna wederom chemotherapie. Daarnaast is er nu ook een nieuwe behandeling, en wel de combinatie van chemotherapie en bestraling. De vraag is nu: is deze nieuwe behandeling beter dan de standaardbehandeling. Om dat te weten te komen moeten wij de twee behandelingen vergelijken.

Het doel van dit fase III onderzoek is om het effect op de overleving van een gecombineerde bestraling en chemotherapie (na de operatie) te vergelijken met die van chemotherapie alleen (ook na de operatie). Tevens zal onderzocht worden hoe patiënten beide behandelvormen verdragen.

Om de onderzoekers in hun keuze van één van beide behandelvormen niet te beïnvloeden, wordt de keuze voor de behandeling door een loting (randomisatie) verricht. Patiënt en arts hebben zo geen invloed op de keuze van behandeling.

Meer informatie over dit type onderzoek vindt u in de folder "Nieuwe behandelingen bij kanker", uitgegeven door het KWF.

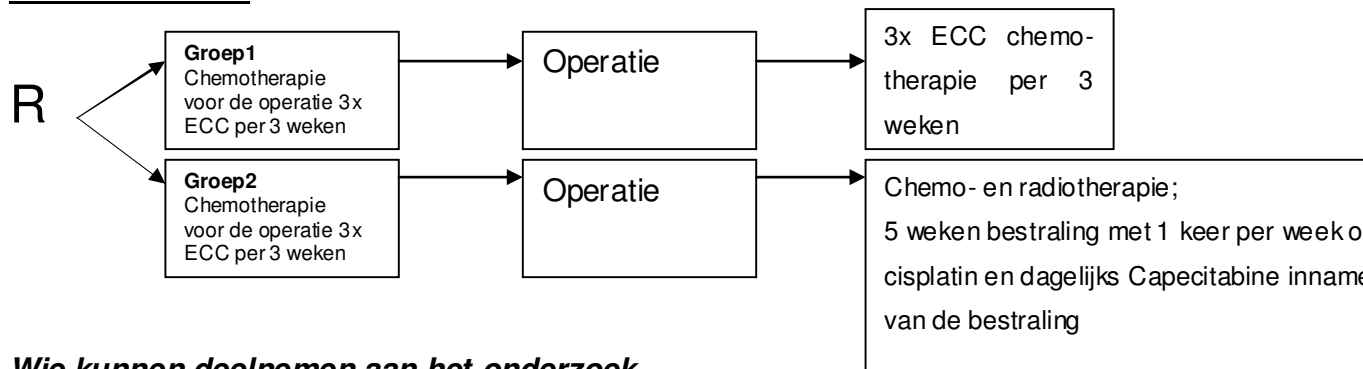
Behandelschema: randomisatie=R**Wie kunnen deelnemen aan het onderzoek**

Patiënten, die geopereerd moeten worden aan maagkanker waarbij de chirurg heeft geoordeeld dat alle zichtbare kankerhaarden verwijderd kunnen worden en bij wie er geen medische redenen zijn om af te zien van narcose. Ook mogen er geen aanwijzingen zijn voor uitzaaiingen buiten het maaggebied.

Wat houdt deelname aan het onderzoek voor u in?

Voorafgaand aan de start van de behandeling zal een aantal onderzoeken en bezoeken aan de betrokken specialisten plaatsvinden. Met deze onderzoeken wordt de uitgebreidheid van de maagtumor bepaald. Dit zijn een gastroscopie (kijkonderzoek van de maag), bloedonderzoek, ECG (hartfilmpje), een longfoto en een CT scan van buik- en borstholte. Deze onderzoeken worden altijd voor een dergelijke maagoperatie gedaan. Ook zal een zogenoemde ejection fractie worden bepaald. Hiervoor krijgt u een kleine hoeveelheid radioactieve stof in een bloedvat in uw arm ingespoten. Deze radioactieve stof heeft geen bijwerkingen en is niet schadelijk voor u. Direct nadat de stof is ingespoten volgt een scan, waarmee we de pompfunctie van het hart onderzoeken.

Bovendien zal er een speciaal nieronderzoek (renogram) verricht worden. Bij het renogram wordt een kleine hoeveelheid radioactief gemerkte stof in een ader gespoten, waarna foto's van de nieren worden gemaakt. Hierbij kan het functioneren van de linker en rechter nier en hun ligging worden vastgelegd. Aangezien maag en linkernier dicht bij elkaar liggen, kan bestraling van het maaggebied een nadelige invloed op de functie van de linkernier hebben. Het renogram is van belang om te bepalen of bestraling op het maaggebied veilig gegeven kan worden of dat het bestralingsschema moet worden aangepast.

Vervolgens beginnen alle patiënten met 3 kuren chemotherapie, voorafgaand aan de operatie. De chemotherapie bestaat uit de celdodende middelen epirubicine, capecitabine en cisplatinum, de zogenoemde ECC kuur.

De ECC kuur

Om de 3 weken een kuur met infusen met epirubicine en cisplatin tijdens een korte ziekenhuisopname (3 dagen en 2 nachten).

Gedurende de eerste twee weken van elke kuur moet u capecitabine-tabletten innemen, gedurende de derde week niet ("vrije week"). Capecitabine wordt tweemaal per dag ingenomen met (of binnen 30 minuten na) het ontbijt en (ongeveer 12 uur later) met (of binnen 30 minuten na) de avondmaaltijd of een lichte snack. De tabletten moeten zonder kauwen worden doorgeslikt met water (geen grapefruitsap). Het aantal tabletten hangt af van uw lengte en lichaamsgewicht.

Cisplatin kan nierbeschadiging geven en wordt via de nieren met de urine uitgescheiden. Het is daarom belangrijk dat de urineproductie voldoende is. Als voorzorgsmaatregel wordt extra vocht via een infuus gegeven vóór, tijdens en na de toediening van cisplatin. Daarbij wordt uw gewicht, de hoeveelheid vocht die u drinkt en toegediend krijgt via het infuus genoteerd, en wordt uw “vochtbalans” bijgehouden. U wordt geadviseerd na de kuur, thuis, ongeveer 1½ tot 2 liter per dag te drinken. Het is belangrijk dat voor elke kuur de nierfunctie wordt gecontroleerd in het bloed.

Bijwerkingen: Deze chemotherapie staat het meest bekend om bijwerkingen als misselijkheid en braken, diarree, slijmvliesbeschadiging in de mond en haaruitval.

Misselijkheid en braken: Bij de 3-wekelijkse kuren worden voorafgaand aan de kuur, via het infuus, medicijnen tegen misselijkheid en braken gegeven, waarmee deze klachten meestal goed kunnen worden bestreden. U krijgt een recept mee voor Kytril en Primperan, voor de bestrijding van eventuele misselijkheid en/of braken thuis. U wordt hierover nog nader geïnformeerd.

Diarree: Als er sprake is van enige diarree dan kan deze klacht met eenvoudige medicijnen (b.v. loperamide: 2 capsules bij diarree en bij elke volgende diarree opnieuw een capsule, maximaal 6 per dag) worden bestreden. Het gebruik van een dergelijk geneesmiddel moet natuurlijk wel met uw arts overlegd worden.

Slijmvliesbeschadiging: Ter voorkoming van pijnlijk slijmvlies van de mond dient u de mond 4 tot 6 maal daags goed te spoelen met een half glas lauwe zoutoplossing (1 liter water met daarin opgelost een theelepeltje zout). Er kan eventueel sucralfaat worden voorgeschreven ter verzachting.

NB: Als u last hebt van ernstige diarree of van zweertjes in de mond, kan de behandeling met capecitabine tijdelijk worden onderbroken. Er zullen dan ook extra bloedcontroles plaatsvinden. Wanneer u deze klachten hebt, moet u contact opnemen met uw behandelend arts. Afhankelijk van de ernst van de klachten, kan de behandeling na een week weer worden hervat met een lagere dosis.

Hand-voet syndroom: Soms veroorzaakt capecitabine pijnlijke/rode handpalmen en voetzolen. Dit kan worden bestreden met een vitamine tabletten (pyridoxine) en eventueel een vette crème. Het hand-voetsyndroom verdwijnt na het staken van capecitabine.

Beenmerg: De aanmaak van de bloedlichaampjes in het beenmerg kan geremd worden door de chemotherapie. Er kan dan een daling van het aantal witte bloedcellen optreden, waardoor u een infectie en koorts kunt krijgen. Als de bloedplaatjes erg laag zijn, kunnen er bloedingen of spontane blauwe plekken optreden. Als deze symptomen voorkomen, dus koorts boven 38.5^o C, blauwe plekken en/of neusbloedingen, moet u contact opnemen met uw behandelend arts of met de nurse practitioner of onderzoeksverpleegkundige. Mogelijk moet u extra naar het ziekenhuis komen voor bloedcontrole en eventueel voor een behandeling met antibiotica of bloedplaatjes toediening via een infuus.

Haarverlies, kaalheid: Dit treedt enkele weken na de behandeling op. Indien u dat wenst kunt u een pruik gaan dragen. Informeer bij uw ziektekostenverzekeringen of deze de

pruik vergoedt. Zonodig kunt u van ons een lijst met adressen krijgen van haarbewerkers/ kappers, bij u in de buurt, die een pruik bij u aan kunnen meten.

Vermoeidheid: Na verloop van tijd treedt er vermoeidheid op door de kuren. Na het beëindigen van de kuren, zal dit weer geleidelijk verdwijnen. De vermoeidheid kan echter ook een andere oorzaak hebben, zoals bloedarmoede door bloedverlies uit de tumor in de maag of door toename van de uitzaaiingen.

De kuren worden zoals gezegd in principe om de drie weken toegediend. Alleen als de bloedwaarden onvoldoende herstel laten zien, wordt de kuur een week uitgesteld.

De operatie

Drie tot zes weken na het einde van de chemotherapie volgt dan de maagoperatie. Het is bij dit type operaties gebruikelijk om tijdens de ingreep een voedings slangetje in de dunne darm te plaatsen om u de eerste tijd na de operatie te kunnen voeden, tot u zelf weer voldoende kunt eten. In het kader van de nabehandeling met chemotherapie al dan niet in combinatie met bestraling wordt geadviseerd om deze te laten zitten tot de gehele behandeling is afgerond. Dit gebeurt om eventuele problemen met de voeding tijdens de nabehandeling eenvoudig te kunnen verhelpen.

Behandeling na de operatie

Afhankelijk van de loting (randomisatie) ontvangt de helft van de patiënten nog 3 van dezelfde ECC chemotherapie kuren. Deze vinden op precies dezelfde wijze plaats als de eerste 3 kuren.

De andere helft van de patiënten begint met de gelijktijdige toediening van radiotherapie en chemotherapie.

Gelijktijdige toediening van chemotherapie en radiotherapie

De **bestraling** vindt plaats gedurende 5 weken van maandag tot en met vrijdag (25 keer), in principe aan het eind van de ochtend (\pm 11.00 uur).

De **chemotherapie** bestaat dit keer uit cisplatin en capecitabine. De cisplatin wordt wekelijks op maandag toegediend en de capecitabine wordt 2 maal daags ingenomen op de dagen dat er bestraald wordt (maandag t/m vrijdag).

De behandeling begint met de inname van de capecitabine, vervolgens de toediening van de cisplatin, gevolgd door een bestraling, meestal vroeg in de middag, 's avonds opnieuw inname van de capecitabine.

De rest van de werkdagen neemt u dagelijks de capecitabine 2 maal daags in en wordt u poliklinisch, meestal laat in de ochtend bestraald.

Cisplatin Voor het toedienen van de cisplatin moet u worden opgenomen.

In de week voor de start van de combinatie behandeling vindt er een zogenaamde "dagopname" plaats.

Dit houdt in dat u op de polikliniek wordt gezien door uw behandelend arts voor een opname consult. Tevens vindt er soms een opname gesprek plaats met de verpleegkundige.

Ter voorbereiding van de behandeling met de Cisplatin, (met de capecitabine en de bestraling) wordt u de avond er voor (meestal zondagavond) opgenomen. Er wordt dan een infuusnaald ingebracht en wordt er 's nachts vocht via het infuus toegediend, Op maandag neemt u de capecitabine in en wordt de cisplatin toegediend, gevolgd door de bestraling en 's avonds neemt u de capecitabine weer in. Gedurende deze opname wordt er gedurende de dag en nacht extra vocht toegediend via het infuus om schade aan de nieren te voorkomen.

De dag na de cisplatin toediening, op dinsdag, kunt u na de bestraling weer naar huis. Dit onder de voorwaarde dat u niet meer misselijk bent, goed kunt drinken en voldoende plast.

U verblijft dus telkens twee nachten en de tussenliggende dag in het ziekenhuis; dit is onvermijdelijk, gezien de toedieningsvoorschriften van de cisplatin.

Capecitabine

De capecitabine neemt u alléén in op de dagen van de bestraling, en nu dus niet in het weekend. Het aantal tabletten wordt ook nu weer berekend op basis van uw lengte en gewicht. Capecitabine moet u 2 maal per dag met water innemen: de "ochtend" tabletten met (of binnen 30 minuten na) het ontbijt (ongeveer 9.00 uur), de "avond" tabletten met (of binnen 30 minuten na) de avondmaaltijd of een snack (ongeveer 21 uur). Het is van belang dat u zich zo goed mogelijk aan deze tijden houdt. Tijdens de behandeling mag u geen grapefruit of grapefruitsap gebruiken.

De tabletten mogen **niet** opnieuw ingenomen worden nadat u overgegeven hebt. U wordt wel verzocht dit te melden aan uw behandelend arts.

De bestraling

In dit onderzoek wordt een hoeveelheid bestraling gegeven die gebruikelijk is om na operaties de kans op het terugkomen van de kanker in het bestraalde gebied te verkleinen. De bestraling bij deze behandeling kan gericht worden toegediend dan vroeger. Het is nu mogelijk om de gezonde organen die rond de maag liggen zo goed mogelijk te sparen. Hierbij zal van de meest moderne apparatuur gebruik worden gemaakt (conebeamCT, IMRT).

Ook zal door de bestralingsarts een plannings-CT-scan worden gemaakt. Aan de hand hiervan wordt het te bestralen gebied uitgerekend. Ook zal het bestralingsveld op de huid worden afgetekend zodat elke keer precies hetzelfde gebied kan worden bestraald (zie ook de folder Radiotherapie van het KWF).

Welke bijwerkingen kunt u verwachten van de combinatie van capecitabine, cisplatin en bestraling?

Capecitabine: Bijwerkingen van capecitabine zijn al eerder uitgebreid beschreven in deze patiënteninformatie: misselijkheid, (zelden) pijnlijke beschadiging van het slijmvlies

in de mond (mucositis) of van de darm, leidend tot diarree, en roodheid en pijn van de huid van handen en voeten (het hand-voet syndroom). Het zogenoemde hand-voetsyndroom kan worden bestreden met een vitamine tabletten (pyridoxine) en eventueel een vette crème. Het hand-voetsyndroom verdwijnt na het staken van capecitabine.

Tegen de diarree kunt u loperamide innemen. (b.v. loperamide: 2 capsules bij diarree en bij elke volgende diarree opnieuw een capsule, maximaal 6 per dag).

Cisplatin: Het is wederom erg belangrijk dat u 1½ tot 2 liter per dag probeert te drinken in verband met de schade die cisplatin kan veroorzaken aan uw nieren, wanneer u onvoldoende vocht binnen krijgt. Mocht het u niet lukken voldoende te drinken, neemt u dan contact op met uw arts of de verpleegkundige. Eventueel kan dan extra vocht toegediend worden via de infuusnaald in uw ader vóór of na de cisplatintoediening.

Andere bijwerkingen van de cisplatin zijn misselijkheid en braken, om dit te voorkomen moet u een half tot 1 uur van tevoren anti-misselijkheidsmedicijnen innemen. Andere, zeldzamere bijwerkingen zijn diarree, een dof gevoel en tintelingen in de vingers en tenen en oorsuizen.

Radiotherapie: De bijwerkingen van *radiotherapie* nemen meestal toe aan het eind van de behandeling. De klachten bestaan veelal uit vermoeidheid, verminderde eetlust, misselijkheid en pijn achter het borstbeen indien dit gebied in het bestralingsveld ligt. Ook pijn bij slikken kan optreden.

Ook aan het einde van deze behandeling kunnen de bloedwaarden verslechteren.

Bij een laag aantal witte bloedcellen bestaat er een toegenomen kans op infecties. Een laag aantal bloedplaatjes kan leiden tot bloedingen, bijv. blauwe plekken of neusbloedingen.

Bij koorts hoger dan 38.5⁰, blauwe plekken en/of bloedingen, maar ook bij de andere boven beschreven bijwerkingen, dient u direct contact op te nemen met uw behandelend arts en de nurse practitioner of onderzoeksverpleegkundige. 's Avonds, 's nachts of in het weekend kunt u met de dienstdoende arts in het ziekenhuis bellen.

Anticonceptie

Van chemotherapie is vaak niet bekend of deze middelen veilig in de zwangerschap kunnen worden gegeven. In dierexperimenten zijn wel schadelijke effecten op het ongeboren jong vastgesteld. Op theoretische gronden is dat ook bij de mens te verwachten. Bestraling van de buikholte leidt tot schade aan het ongeboren kind. Daarom mogen patiënten tijdens de behandeling niet zwanger worden of kinderen verwekken. Goede anticonceptie is dus noodzakelijk. Bespreek dit met uw arts.

Mogelijke voor- en nadelen van meedoen

Uw behandeling bevat in ieder geval de huidige standaardbehandeling voor maagkanker, namelijk de maagoperatie. Onderzoek heeft aangetoond dat aanvullende behandeling voor of na operatie leidt tot overlevingswinst. Het is niet zeker of dat ook bij u het geval zal zijn. Het zou kunnen zijn dat het door ons gekozen behandelingschema te zwaar is en tot een toename van bijwerkingen leidt. Met een intensieve begeleiding door alle betrokken specialisten, diëtisten en verpleegkundigen en door bloedonderzoek zullen wij uw conditie nauwlettend in de gaten houden en samen met u de balans tussen werkzaamheid en verdraagbaarheid van de behandeling bewaken.

Extra weefselonderzoek

Graag willen wij een stukje van het tijdens de operatie verkregen tumorweefsel gebruiken voor wetenschappelijk onderzoek. Dit weefsel wordt door de patholoog microscopisch onderzocht en beschreven. Daarnaast wordt een extra stukje weefsel opgeslagen, om in de toekomst met weefselonderzoek of onderzoek naar erfelijke kenmerken van het tumorweefsel te kunnen voorspellen welke behandeling het meest geschikt is voor iedere individuele maagkankerpatiënt. Ook willen we voor hetzelfde soort wetenschappelijk onderzoek graag wat van het afgenomen bloed bewaren.

In principe is de uitslag van dit onderzoek niet van belang voor uw behandeling. U krijgt de uitslag dan ook niet te horen. Er is een kleine kans dat de uitslag van onderzoek naar erfelijke kenmerken toch voor u van belang kan zijn. In de toestemmingsverklaring kunt u aangeven of u, in dat geval, toch de uitslag wilt weten. Uw arts kan u bij het nemen van die beslissing helpen.

Deelname aan dit gedeelte van het onderzoek is niet verplicht, en u dient hiervoor een apart onderdeel van het toestemmingsformulier te tekenen. Indien u eventueel afziet van dit onderdeel van het onderzoek, kunt u toch aan de rest van het onderzoek meedoen.

Afzien van deelname of beëindiging van deelname

Deelname aan deze behandeling in onderzoeksverband vindt alleen plaats, indien u daarvoor uitdrukkelijk toestemming verleent. Uw deelname is uiteraard geheel vrijwillig. U kunt dus vrijelijk besluiten niet aan dit onderzoek deel te nemen. Indien u tijdens de behandeling wilt stoppen, zal uw behandelend arts samen met u overleggen over de beste mogelijkheden om u verder te helpen.

Privacy

Als u toestemming tot deelname aan het onderzoek geeft, houdt dit tevens in dat u toestemming geeft om in het kader van dit onderzoek verzamelde medische gegevens en eventueel afgenomen lichaamsmateriaal (verwijderd weefsel bij operatie, bloedmonsters) kunnen worden gebruikt voor verdere analyse. Vanzelfsprekend zullen al uw gegevens vertrouwelijk worden behandeld. De gegevens en het lichaamsmateriaal zullen van een code worden voorzien, niet van uw persoonsgegevens.

Behalve uw arts en zijn/haar vaste medewerkers zullen alleen daartoe wettelijk bevoegde personen/vertegenwoordigers van toezichthoudende instanties uw medische gegevens kunnen inzien. Dit zijn bijvoorbeeld vertegenwoordigers van overheidsinstanties en daartoe bevoegde personen van de medisch ethische toetsingscommissie van het Nederlands Kanker Instituut/Antoni van Leeuwenhoekziekenhuis (NKI-AVL). Hierbij zal strikte vertrouwelijkheid in acht worden genomen. Door toe te stemmen in deelname aan dit onderzoek, geeft u ook uw toestemming voor het inzien in uw medische gegevens. Mocht u hier bezwaar tegen hebben of hier meer over willen weten, bespreekt u dit dan met uw behandelend arts.

Er zullen geen andere gegevens verzameld worden dan in het kader van dit onderzoek nodig is. Ten slotte zullen uw gegevens niet in herleidbare vorm gepubliceerd worden of voor derden toegankelijk zijn.

Verzekering

Conform de eisen van de Wet Medisch Onderzoek bij mensen is voor dit wetenschappelijk onderzoek een verplichte proefpersonenverzekering afgesloten. Informatie hierover valt te lezen in de bijgevoegde bijlage.

Goedkeuring

Dit onderzoek is goedgekeurd door de Protocol Toetsing Commissie (medisch ethische toetsingscommissie) van het NKI/AVL.

Vragen

Indien u vragen heeft over de behandeling in het kader van dit onderzoek, dan kunt u zich wenden tot

- uw behandelend arts

of tot een van de coördinatoren van het onderzoek:

- Prof. dr. C.J.H. van de Velde, chirurg in het Leids Universitair Medisch Centrum, telefoon 071-5262309 of
- Dr. H. Boot en Dr. A. Cats, maag-darm-leverartsen in het NKI/AVL, telefoon 020-5122566 of
- Prof. dr. M. Verheij en E. Jansen, radiotherapeuten in het NKI/AVL, telefoon 020-5122124.

Bij problemen buiten kantooruren kunt u contact opnemen met de dienstdoende arts via het algemene nummer van het ziekenhuis 020-5129111.

Bij vragen over het onderzoek kunt u zich wenden tot de onafhankelijk arts van dit onderzoek Dr. J.M. Kerst, internist in het NKI/AVL, telefoon 020-5122951.

bijlage proefpersonenverzekering **CRITICS-studie**

Onderzoek naar het verschil in effect tussen gecombineerde chemotherapie en bestraling vergeleken met chemotherapie alleen, na chemotherapie en operatieve behandeling van maagkanker.

Een fase III studie waarin het effect van bestraling met gelijktijdige chemotherapie na operatie wordt vergeleken met chemotherapie alleen.

Oorspronkelijke Engelse titel: A multicenter randomized phase III trial of neo-adjuvant chemotherapy followed by surgery and chemotherapy or by surgery and chemoradiotherapy in resectable gastric cancer (CRITICS-study: ChemoRadiotherapy after Induction chemoTherapy In Cancer of the Stomach)

Voor de deelnemers aan dit onderzoek is een verzekering afgesloten. Deze verzekering dekt schade door dood of letsel die het gevolg is van deelname aan het onderzoek, en die zich gedurende de deelname aan het onderzoek openbaart, of binnen vier jaar na beëindiging van de deelname aan het onderzoek. De schade wordt geacht zich te hebben geopenbaard wanneer deze bij de verzekeraar is gemeld.

De verzekering biedt een maximum dekking van € 450.000,- per proefpersoon, € 3.500.000,- voor het gehele onderzoek, en € 5.000.000,- per jaar voor alle onderzoeken van dezelfde opdrachtgever. De dekking van specifieke schades en kosten is verder tot bepaalde bedragen beperkt. Dit is opgenomen in het Besluit verplichte verzekering bij medisch-wetenschappelijk onderzoek met mensen. Informatie hierover kunt u vinden op de website van de Centrale Commissie Mensgebonden Onderzoek: www.ccmo.nl.

Voor deze verzekering gelden een aantal uitsluitingen. De verzekering dekt niet:

- schade waarvan op grond van de aard van het onderzoek zeker of nagenoeg zeker was dat deze zich zou voordoen;
- schade aan de gezondheid die ook zou zijn ontstaan indien u niet aan het onderzoek had deelgenomen;
- schade die het gevolg is van het niet of niet volledig nakomen van aanwijzingen of instructies;
- schade aan nakomelingen, als gevolg van een nadelige inwerking van het onderzoek op u of uw nakomeling;
- bij onderzoek naar bestaande behandelmethoden: schade die het gevolg is van één van deze behandelmethoden;
- bij onderzoek naar de behandeling van specifieke gezondheidsproblemen: schade die het gevolg is van het niet verbeteren of van het verslechteren van deze gezondheidsproblemen.

In geval van schade kunt u zich direct wenden tot de verzekeraar.

Naam: Gerling Allgemeine Versicherungs-AG
Adres: Postbus 2636
1000 CP Amsterdam
Telefoonnummer: 020 – 54 92 213
Contactpersoon: Mr. P. Oosterveen



Schriftelijke toestemming voor klinisch wetenschappelijk onderzoek **CRITICS-studie**

Onderzoek naar het verschil in effect tussen gecombineerde chemotherapie en bestraling vergeleken met chemotherapie alleen, na chemotherapie en operatieve behandeling van maagkanker. Een fase III studie waarin het effect van bestraling met gelijktijdige chemotherapie na operatie wordt vergeleken met chemotherapie alleen.

Oorspronkelijke Engelse titel: A multicenter randomized phase III trial of neo-adjuvant chemotherapy followed by surgery and chemotherapy or by surgery and chemoradiotherapy in resectable gastric cancer (CRITICS-study: ChemoRadiotherapy after Induction chemoTherapy In Cancer of the Stomach)

Ik ben over bovengenoemd wetenschappelijk onderzoek geïnformeerd door de informant die dit formulier hieronder mede ondertekent.

Ik heb de schriftelijke informatie die mij is uitgereikt, goed bestudeerd. Ik ben in de gelegenheid gesteld om vragen over het onderzoek te stellen. Ik heb voldoende tijd gehad om goed over deelname aan het onderzoek na te denken.

Ik stem toe met deelname aan bovengenoemd onderzoek. Ik geef toestemming tot inzage van mijn medisch dossier door bevoegden, zoals omschreven in de patiënteninformatie.

Achternaam en voorletters:

Geboortedatum:

Handtekening:

Dagtekening:

Ik stem er wel/niet * in toe dat een deel van het weefsel of het bloed wordt bewaard om hier in de toekomst wetenschappelijk onderzoek mee te doen dat van belang kan zijn voor betere diagnose en behandeling van maagkanker. (* doorhalen van het van toepassing is)

Paraaf: _____

In het (weinig waarschijnlijke) geval dat er bij later onderzoek aan het tumorweefsel of het bloed erfelijke informatie wordt verkregen die voor mij van belang kan zijn, wil ik hier graag wel / niet / afhankelijk van aanvullende informatie verstrekt door mijn arts * van op de hoogte worden gesteld. (* doorhalen van het van toepassing is)

Paraaf: _____

Ondergetekende verklaart dat de hierboven genoemde persoon over het bovenvermelde onderzoek geïnformeerd is.

Naam:

Functie:

Handtekening:

Dagtekening:

NB. Het origineel van de toestemmingsverklaring dient in het medisch dossier van de patiënt bewaard te worden



Patiënteninformatie (deel 2)

Bijlage bij de CRITICS studie betreffende genetisch onderzoek in weefsel en bloed

Titel van het hoofdonderzoek:

Onderzoek naar het verschil in effect tussen gecombineerde chemotherapie en bestraling vergeleken met chemotherapie alleen, na chemotherapie en operatieve behandeling van maagkanker.

Een fase III studie waarin het effect van bestraling met gelijktijdige chemotherapie na operatie wordt vergeleken met chemotherapie alleen

Geachte mevrouw, meneer,

Een optioneel (niet verplicht) onderdeel van het onderzoek betreft de extra afname van tumorweefsel ten behoeve van genetisch (DNA-) onderzoek.

Wij willen wij u vragen vlak voor de start van de behandeling met chemotherapie een (extra) gastroscopie te ondergaan met als doel het verkrijgen van een stukje tumorweefsel. Dit weefsel wordt gebruikt voor wetenschappelijk onderzoek.

Voordat u besluit of u zou willen deelnemen aan dit onderdeel van het onderzoek, willen we u graag wat meer informatie hierover geven.

Wat is DNA?

De cellen in uw lichaam bevatten een type molecuul dat desoxyribonucleïnezuur wordt genoemd, kortweg DNA. DNA vormt de basis van uw genen. Genen worden geërfd en bepalen de groei, de ontwikkeling en het functioneren van het lichaam. Sommige genen bepalen bijvoorbeeld de kleur van het haar of de ogen. Wetenschappers hebben al veel kennis vergaard over de werking van genen en tussen het DNA van mensen bestaan veel verschillen of variaties.

Deze variaties kunnen invloed hebben op de kans om een bepaalde ziekte te krijgen of op de manier waarop iemand op een bepaalde behandeling reageert.

In het tumorweefsel kan een deel van de DNA-structuur worden bepaald.

Wat gebeurt er met het tumorweefsel?

Het tumorweefsel wordt opgeslagen, om in de toekomst, met weefselonderzoek of onderzoek naar erfelijke kenmerken van het tumorweefsel, te kunnen voorspellen welke behandeling het meest geschikt is voor iedere individuele maagkankerpatiënt.

In principe is de uitslag van dit onderzoek niet van belang voor uw behandeling. U krijgt de uitslag dan ook niet te horen. Er is een kleine kans dat de uitslag van onderzoek naar erfelijke kenmerken toch voor u van belang kan zijn. In de toestemmingsverklaring kunt u aangeven of u, in dat geval, toch de uitslag wilt weten. Uw arts kan u bij het nemen van die beslissing helpen.

Dit kunnen we vervolgens vergelijken met medische informatie over u.

Wat zijn de mogelijke risico's en ongemakken waarmee deelname gepaard gaat?

Voor het verkrijgen van het tumorweefsel moet u een extra gastroscopie ondergaan. Een gastroscopie is een kijkonderzoek in de slokdarm, maag en de twaalfvingerige darm. Voor dit onderzoek moet een buigzame slang met een lampje (gastroscoop) inslikken. De gastroscoop wordt verder opgeschoven naar de maag en de twaalfvingerige darm. Tijdens dit onderzoek kunnen (tumor)weefselstukjes worden weggenomen voor het onderzoek .

Wanneer weefselstukjes van het slijmvlies zijn genomen is er een klein risico op bloedverlies. U merkt dit doordat de ontlasting, de dag na het onderzoek, zwart is en stinkt of heel zelden het opbraken van bloed. Bij bloedverlies moet u altijd contact opnemen met het ziekenhuis.

Voor verdere informatie over de gastroscopie kunt u de folder: "Kijkonderzoek in slokdarm en maag" lezen, deze is verkrijgbaar bij het Onderzoeks-en Behandelcentrum op de 2e etage.

Wat zijn de mogelijke voordelen van deelname?

U heeft geen rechtstreeks voordeel bij deelname aan dit deel van het onderzoek.

Dit onderzoek draagt er echter mogelijk wel toe bij dat we meer inzicht krijgen in kanker en de behandeling ervan, wat uiteindelijk tot verbetering van de behandeling kan leiden.

Ben ik verplicht om deel te nemen?

Deelname aan dit gedeelte van het onderzoek is niet verplicht, u beslist zelf of u aan dit genetische onderzoek wilt deelnemen of niet. U kunt op elk moment weigeren om een monster af te staan zonder dat dit nadelige gevolgen voor u heeft. U krijgt dezelfde behandeling en zorg als in het hoofdonderzoek, ongeacht of u wel of niet een weefselmonster afstaat voor genetisch onderzoek zoals beschreven in dit document. Als u besluit om geen weefselmonster af te staan, kunt u toch gewoon aan het hoofdonderzoek deelnemen

Wanneer u wel toestemming geeft voor de gastroscopie en de afname van het tumorweefsel dient hiervoor een apart toestemmingsformulier te tekenen.

Kan ik mijn toestemming intrekken?

U kunt uw toestemming voor het gebruik van uw weefsel bij genetisch onderzoek te allen tijde intrekken. Als u uw toestemming intrekt **voordat** uw tumor bloedmonster wordt opgestuurd voor genetisch onderzoek, dan zal de onderzoeksarts ervoor zorgen dat dit wordt vernietigd. Als u uw toestemming intrekt **nadat** uw bloedmonster voor genetisch onderzoek is opgestuurd, dan zorgt de onderzoeksarts ervoor dat uw tumorweefsel en het DNA dat er eventueel uit is gehaald, worden vernietigd. Als het genetisch onderzoek echter al heeft plaatsgevonden, dan is de onderzoekssponsor niet verplicht om de resultaten van dit onderzoek te vernietigen.

Vertrouwelijkheid

Er worden speciale voorzorgsmaatregelen genomen om te garanderen dat het onderzoek met een zeer grote mate van vertrouwelijkheid wordt uitgevoerd.

Uw tumorweefsel wordt van een etiket voorzien met dezelfde code als die u bij het hoofdonderzoek is toegekend, maar zonder informatie waaraan u direct te herkennen zou kunnen zijn, zoals uw naam.

Monsters en resultaten worden gecodeerd om te garanderen dat resultaten van genetisch onderzoek vertrouwelijk blijven door uw identiteit en de resultaten apart te houden. Zeer weinig mensen zullen uw identiteit en de resultaten van DNA-onderzoek met elkaar kunnen verbinden en dat gebeurt alleen om speciale redenen, bijvoorbeeld wanneer daar een medische noodzaak voor is

De gegevens en resultaten van dit genetische onderzoek worden mogelijk met medewerkers beoordeeld en gepubliceerd. Uw naam of andere informatie die u uw identiteit zouden kunnen verraden, zullen in geen enkele publicatie en geen enkel rapport worden vermeld.

Verzekering

Conform de eisen van de Wet Medisch Onderzoek bij mensen is voor dit wetenschappelijk onderzoek een verplichte proefpersonenverzekering afgesloten. Informatie hierover valt te lezen in de bijgevoegde bijlage.

Goedkeuring

Dit onderzoek is goedgekeurd door de Protocol Toetsing Commissie (medisch ethische toetsingscommissie) van het NKI - AVL.

Met wie moet ik contact opnemen voor meer informatie of hulp?

Indien u vragen heeft over de behandeling in het kader van dit onderzoek, dan kunt u zich wenden tot

Uw behandelend arts of tot een van de coördinatoren van de CRITICS studie:

- Dr. H. Boot en dr. A. Cats, maag-darm-leverartsen in het NKI/AVL, telefoon 020-5122566 of
- Prof. dr. M. Verheij en dr. E. Jansen, radiotherapeuten in het NKI/AVL, telefoon 020-5122124.

Bij problemen buiten kantooruren kunt u contact opnemen met de dienstdoende arts via het algemene nummer van het ziekenhuis 020-5129111.

Bij vragen over het onderzoek kunt u zich wenden tot de onafhankelijk arts van dit onderzoek Dr. J.M. Kerst, internist in het NKI/AVL, telefoon 020-5122951.



Onderzoek naar het verschil in effect tussen gecombineerde chemotherapie en bestraling vergeleken met chemotherapie alleen, na chemotherapie en operatieve behandeling van maagkanker.

Een fase III studie waarin het effect van bestraling met gelijktijdige chemotherapie na operatie wordt vergeleken met chemotherapie alleen.

Oorspronkelijke Engelse titel: A multicenter randomized phase III trial of neo-adjuvant chemotherapy followed by surgery and chemotherapy or by surgery and chemoradiotherapy in resectable gastric cancer (CRITICS-study: ChemoRadiotherapy after Induction chemoTherapy In Cancer of the Stomach).

Ik ben over bovengenoemd wetenschappelijk onderzoek geïnformeerd door de informant die dit formulier hieronder mede ondertekent.

Ik heb de schriftelijke informatie die mij is uitgereikt, goed bestudeerd. Ik ben in de gelegenheid gesteld om vragen over het onderzoek te stellen. Ik heb voldoende tijd gehad om goed over deelname aan het onderzoek na te denken.

Ik stem toe met deelname aan bovengenoemd onderzoek. Ik geef toestemming tot inzage van mijn medisch dossier door bevoegden, zoals omschreven in de patiënteninformatie.

Achternaam en voorletters

:

Geboortedatum:

Handtekening:

Dagtekening

Paraaf:

In het (weinig waarschijnlijke) geval dat er bij later onderzoek aan het tumorweefsel of het bloed erfelijke informatie wordt verkregen die voor mij van belang kan zijn, wil ik hier graag wel / niet / afhankelijk van aanvullende informatie verstrekt door mijn arts * van op de hoogte worden gesteld. (* doorhalen van het van toepassing is)

Paraaf:

Ondergetekende verklaart dat de hierboven genoemde persoon over het bovenvermelde onderzoek geïnformeerd is.

Naam:

Functie:

Paraaf:

Dagtekening:

APPENDIX B) WHO CLASSIFICATION

World Health Organisation (WHO) Performance Status	
0	Fully active; able to carry on all pre-disease performance (normal activity) without restriction
1	Restricted in physically strenuous activity but ambulatory and able to carry out work of a light or sedentary nature
2	Ambulatory and capable of all selfcare but unable to carry out any work activities; up and about more than 50% of waking hours
3	Capable of only limited selfcare; confined to bed or chair more than 50% of waking hours
4	Completely disabled; cannot carry on any selfcare; totally confined to bed or chair
5	Dead

APPENDIX C) QUALITY OF LIFE QUESTIONNAIRES

DUTCH



EORTC QLQ-C30 (version 3)

Wij zijn geïnteresseerd in bepaalde dingen over u en uw gezondheid. Wilt u alle vragen zelf beantwoorden door het getal te omcirkelen dat het meest op u van toepassing is. Er zijn geen "juiste" of "onjuiste" antwoorden. De informatie die u geeft zal strikt vertrouwelijk worden behandeld.

Wilt u uw initialen invullen:

Uw geboortedatum (Dag, Maand, Jaar):

De datum van vandaag (Dag, Maand, Jaar):

 31

	Helemaal niet	Een beetje	Nogal	Heel erg
1. Heeft u moeite met het doen van inspannende activiteiten zoals het dragen van een zware boodschappentas of een koffer?	1	2	3	4
2. Heeft u moeite met het maken van een <u>lange</u> wandeling?	1	2	3	4
3. Heeft u moeite met het maken van een <u> korte</u> wandeling buitenshuis?	1	2	3	4
4. Moet u overdag in bed of op een stoel blijven?	1	2	3	4
5. Heeft u hulp nodig met eten, aankleden, uzelf wassen of naar het toilet gaan?	1	2	3	4

Gedurende de afgelopen week:

	Helemaal niet	Een beetje	Nogal	Heel erg
6. Was u beperkt bij het doen van uw werk of andere dagelijkse bezigheden?	1	2	3	4
7. Was u beperkt in het uitoefenen van uw hobby's of bij andere bezigheden die u in uw vrije tijd doet?	1	2	3	4
8. Was u kortademig?	1	2	3	4
9. Heeft u pijn gehad?	1	2	3	4
10. Had u behoefte om te rusten?	1	2	3	4
11. Heeft u moeite met slapen gehad?	1	2	3	4
12. Heeft u zich slap gevoeld?	1	2	3	4
13. Heeft u gebrek aan eetlust gehad?	1	2	3	4
14. Heeft u zich misselijk gevoeld?	1	2	3	4

Wilt u a.u.b. naar de volgende bladzijde gaan

DUTCH

Gedurende de afgelopen week:	Helemaal niet	Een beetje	Nogal	Heel erg
15. Heeft u overgegeven?	1	2	3	4
16. Had u last van obstipatie? (was u verstopt?)	1	2	3	4
17. Had u diarree?	1	2	3	4
18. Was u moe?	1	2	3	4
19. Heeft pijn u gehinderd in uw dagelijkse bezigheden?	1	2	3	4
20. Heeft u moeite gehad met het concentreren op dingen, zoals een krant lezen of televisie kijken?	1	2	3	4
21. Voelde u zich gespannen?	1	2	3	4
22. Maakte u zich zorgen?	1	2	3	4
23. Voelde u zich prikkelbaar?	1	2	3	4
24. Voelde u zich neerslachtig?	1	2	3	4
25. Heeft u moeite gehad met het herinneren van dingen?	1	2	3	4
26. Heeft uw lichamelijke toestand of medische behandeling uw <u>familieleven</u> in de weg gestaan?	1	2	3	4
27. Heeft uw lichamelijke toestand of medische behandeling u belemmerd in uw <u>sociale</u> bezigheden?	1	2	3	4
28. Heeft uw lichamelijke toestand of medische behandeling financiële moeilijkheden met zich meegebracht?	1	2	3	4

Wilt u voor de volgende vragen het getal tussen 1 en 7 omcirkelen dat het meest op u van toepassing is

29. Hoe zou u uw algehele gezondheid gedurende de afgelopen week beoordelen?

1 2 3 4 5 6 7

Erg slecht

Uitstekend

30. Hoe zou u uw algehele "kwaliteit van het leven" gedurende de afgelopen week beoordelen?

1 2 3 4 5 6 7

Erg slecht

Uitstekend

DUTCH



EORTC QLQ – STO22

Soms zeggen patienten dat ze de volgende klachten of problemen hebben. Wilt u aangeven in welke mate u deze klachten of problemen gedurende de afgelopen week heeft ervaren door het getal te omcirkelen dat het meest op u van toepassing

Gedurende de afgelopen week:	Helemaal niet	Een beetje	Nogal	Heel erg
31. Had u problemen bij het eten van vast voedsel?	1	2	3	4
32. Had u problemen bij het eten van vloeibaar of zacht voedsel?	1	2	3	4
33. Had u problemen bij het drinken van vloeistoffen?	1	2	3	4
34. Voelde u zich ongemakkelijk bij het eten?	1	2	3	4
35. Had u pijn in de maagstreek?	1	2	3	4
36. Had u last in de maagstreek?	1	2	3	4
37. Had u een opgeblazen gevoel in uw buik?	1	2	3	4
38. Had u last van zuur of gal in de mond?	1	2	3	4
39. Had u indigestie of maagzuur?	1	2	3	4
40. Had u last van oprispingen?	1	2	3	4
41. Had u het gevoel sneller dan normaal voldaan te zijn als u at?	1	2	3	4
42. Had u er moeite mee van uw maaltijden te genieten?	1	2	3	4
43. Had u veel tijd nodig om uw maaltijden te beëindigen?	1	2	3	4
44. Had u een droge mond?	1	2	3	4
45. Smaakten voedsel en drank anders dan gewoonlijk?	1	2	3	4
46. Had u problemen om in aanwezigheid van anderen te eten?	1	2	3	4
47. Dacht u aan uw ziekte?	1	2	3	4
48. Heeft u zich zorgen gemaakt dat uw gewicht te laag is?	1	2	3	4
49. Voelde u zich lichamelijk minder aantrekkelijk ten gevolge van uw ziekte of behandeling	1	2	3	4
50. Maakte u zich zorgen over uw toekomstige gezondheidstoestand?	1	2	3	4
51. Heeft u haaruitval gehad?	1	2	3	4
52. Deze vraag alleen invullen indien u haaruitval heeft gehad: Was u door het verlies van uw haar van streek?	1	2	3	4

**APPENDIX D)
COMMON TERMINOLOGY CRITERIA FOR ADVERSE EVENTS**

In the present study, toxicities will be recorded according to the Common Terminology Criteria for Adverse Events (CTCAE), version 3.0. The full CTC document is available at the following web site

<http://ctep.cancer.gov/reporting/ctc.html>

Investigators who do not have access to Internet can contact the Data Centre to receive a hard copy of this document by mail.

APPENDIX E**Dose calculations and modifications.capecitabine according to BSA.**For capecitabine **1000 mg/m² bid** (100% dose level)

BSA	Total daily dose	Tablets/ day	Tablets/ day	Total tablets	Total tablets	Prescription	Prescription
		150 mg	500 mg	for 14 days 150 mg	for 14 days 500 mg	Morning + evening 150 mg	Morning + evening 500 mg
≤1,22	2300	2	4	28	56	1+1	2+2
1,23 - 1,40	2600	4	4	56	56	2+2	2+2
1,41 - 1,57	3000	0	6	0	84	0	3+3
1,58 - 1,72	3300	2	6	28	84	1+1	3+3
1,73 - 1,90	3600	4	6	56	84	2+2	3+3
≥ 1,91	4000	0	8	0	112	0	4+4

For capecitabine **750 mg/m² bid** (75% dose level)

BSA	Total daily dose	Tablets/ day	Tablets/ day	Total tablets	Total tablets	Prescription	Prescription
		150 mg	500 mg	for 14 days 150 mg	for 14 days 500 mg	Morning + evening 150 mg	Morning + evening 500 mg
≤1,22	1650	1	3	14	42	0+1	1+2
1,23 - 1,40	2000	0	4	0	56	0	2+2
1,41 - 1,57	2300	2	4	28	56	1+1	2+2
1,58 - 1,90	2500	0	5	0	70	0	2+3
≥ 1,91	3000	0	6	0	84	0	3+3

For capecitabine **500 mg/m² bid** (50% dose level)

BSA	Total daily dose	Tablets/ day	Tablets/ day	Total tablets	Total tablets	Prescription	Prescription
		150 mg	500 mg	for 14 days 150 mg	for 14 days 500 mg	Morning + evening 150 mg	Morning + evening 500 mg
≤1,22	1150	1	2	14	28	0+1	1+2
1,23 - 1,40	1300	2	2	28	28	1+1	1+1
1,41 - 1,57	1500	0	3	0	42	0	1+2
1,58 - 1,72	1650	1	3	14	42	0+1	1+2
1,73 - 1,90	1800	2	3	28	42	1+1	1+2
≥ 1,91	2000	0	4	0	56	0	2+2

APPENDIX F) Optional gastroscopy

If the patient agrees with the additional gastroscopy, this gastroscopy should be performed before the start of the chemotherapeutic treatment.

As many biopsies as possible (up to 20 and a minimum of 12) will be collected. Half of these biopsies should be put in formaldehyde and half of them should be put in RNA later:

The tubes with RNA will be provided by the Dept. of Pathology of the Vrije Universiteit Medical centre (VUMC) together with an envelope. This material should be send to the dept. of Pathology of the VUMC the same day for further treatment of the tissue.

The biopsies in formaldehyde should be routinely send to the local pathology department for fixation and embedding in paraffin. The paraffin blocks will be collected by and stored in the VUMC together with the tissue collected from the gastrectomy specimens.

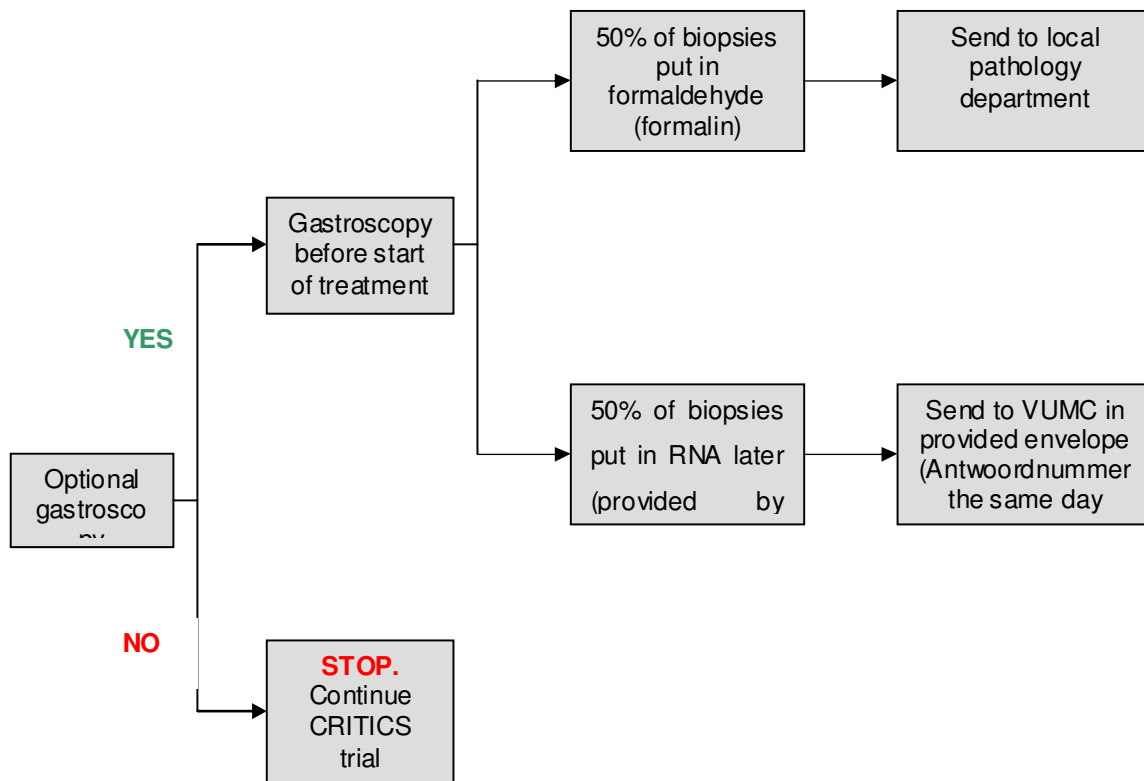



APPENDIX F) Collection of biopsies by optional gastroscopy
Afname biopten CRITICS-studie

Randomisatienummer: _____

Geboortedatum: _____

Datum gastroscopie: _____

Protocol verzameling biopten :

1. De gastroscopie wordt verricht volgens de normale procedure.
2. Maximaal 20 en minimaal 12 biopten worden afgenomen van de tumor.
3. Biopten worden om en om verzameld in formaline en RNA later.
4. De potjes met formaline worden routinematig verstuurd naar het locale pathologie laboratorium voor routine verwerking.
5. Op de tubes met RNA later wordt vermeld: CRITICS, randomisatienummer en datum van de gastroscopie.
6. De tubes met RNA later worden dezelfde dag (binnen 24 uur) verstuurd in de aangeleverde Antwoordenvelppen.

Aantal biopten op formaline : _____

Aantal biopten in RNA later : _____

**VERGEET NIET HET RANDOMISATIENUMMER EN SCOPIEDATUM
OP DE TUBES TE VERMELDEN !!**

Voor vragen kunt u contact opnemen met:

Nicole van Grieken
Afdeling Pathologie
VUMC

020-4444154

nct.vangrieken@vumc.nl

of bgg:

VUMC

Gerrit Meijer
Afdeling Pathologie

020-4444772

ga.meijer@vumc.nl

APPENDIX G) Collection of blood for translational research



Bloedafname CRITICS-studie

Randomisatienummer: _____

Geboortedatum: _____

Afnamedatum: _____

- Deze afname is :
- Pre-study
 - Pre-operative
 - Before start of adjuvant therapy
 - After final treatment
 - After ... year(s) follow-up

Afname protocol :

7. De patient zit rustig op een stoel.
8. Met een serum separator vacutainer tube wordt er veneus bloed uit de elleboog afgenomen.
9. Het bloed wordt afgenomen in 3 buizen van 7-10 ml in heparine, citraat of EDTA.
10. Op de buizen wordt vermeld: CRITICS, randomisatienummer en afnamedatum.
11. De buizen worden dezelfde dag (binnen 24 uur) verstuurd in de aangeleverde Antwoordenveloppen.

**VERGEET NIET HET RANDOMISATIENUMMER EN AFNAMEDATUM
OP DE BUIZEN TE VERMELDEN !!**

Voor vragen kunt u contact opnemen met:

Nicole van Grieken
Afdeling Pathologie
3.08
VUMC
020-4444154

of bgg:

Astrid Greijer
Cancer Center Amsterdam, room

nct.vangrieken@vumc.nl

VUMC
020-4444052
ae.greijer@vumc.nl